

## Overview

The 83KM/93KM–85KM/95KM IDH Max 1300 Cylindrical Lock provides the following features in an integrated lock, eliminating the need to install separate sensors in and around the door frame:

- electrified locking mechanism
- electronic token reader
- integrated trim
- door status detection
- ability to exit without triggering an alarm

The figure below shows the relationship between the components in the IDH Max system.

## Contents

These installation instructions describe how to install, wire, and configure the components provided with your 83KM/93KM–85KM/95KM IDH Max Cylindrical Lock. The following topics are covered.

<i>Site survey</i> .....	2
<i>Components checklist</i> .....	2
<i>Special tools checklist</i> .....	3
<i>Preparing the door and door jamb</i> .....	4
<i>Installing the lock</i> .....	10
<i>Completing the installation at the door</i> .....	19
<i>Testing the installation</i> .....	21
<i>Troubleshooting the installation</i> .....	22

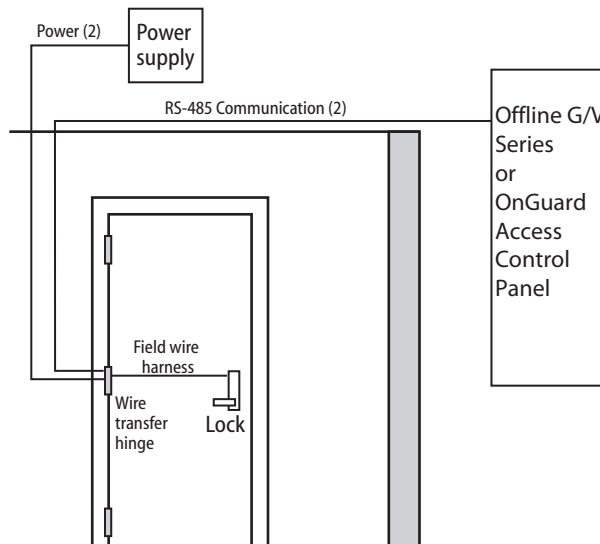

## Site survey

Use the following survey to record information about the installation site. You need this information to determine field wiring needs, select a power supply, and determine how to prepare the door for the lock.

### Lock information

Lock function:

- DDEL—Electrically locked
- DDEU—Electrically unlocked

Power source for lock:

- Separate power supply
- Power provided through panel interface module

Power source for panel interface module:

- Separate power supply
- Power provided through access control panel

Distance of lock site from lock power source: \_\_\_\_\_ feet

Distance of lock site from panel interface module site:  
\_\_\_\_\_ feet

### Door information

Door handing and bevel:

- Left hand (LH)
- Left hand, reverse bevel (LHRB)
- Right hand (RH)
- Right hand, reverse bevel (RHRB)

Door thickness: \_\_\_\_\_ inches (1 3/4" – 2 1/4"; 1 3/8" with spacer)

### Environment information

Ambient temperature:

- Is within specifications. See the tables below.

This product meets the following Locked Door Outdoor test requirements for ANSI/BHMA 156.25:

Side of door	Range
Inside	+66°F to +74°F (+19°C to +23°C)
Outside	–31°F to +151°F (–35°C to +66°C)

This product meets the following Full Indoor test requirements for ANSI/BHMA 156.25:

Side of door	Range
Inside and outside	+32°F to +120°F (0°C to +49°C)

Use the following checklist to make sure that you have the items necessary to install the components provided with your 83KM/93KM–85KM/95KM IDH Max Cylindrical Lock.

### Components provided in the box:

- Chassis with outside knob/lever and outside rose liner assembly
- Fire plate assembly with field wire harness, PCB board and holders
- Top and bottom inside covers
- Inside rose liner with RQE feature
- Outside escutcheon assembly
- Inside knob/lever
- Throw member package\*
- Sleeve bushing\*
- Latch
- Door status switch & magnet assembly
- Plastic bushing package
- Hub washers
- Trim hole insert package
- Escutcheon screw package
- Strike package
- Bar code ID sticker (for your records)

### Other items you'll need:

- Power supply for one IDH Max Cylindrical Lock (if you're providing a separate power supply): regulated; 12 volts DC at .85 amps

**Note:** *If you intend to power more than one lock with the same power supply, calculate the amperage for the power supply by multiplying .85 by the number of IDH Max Cylindrical Locks (1.1 by the number of IDH Max Mortise Locks).*

- Wire transfer hinge: 8 conductors min.; 28 AWG min.  
*continued*

\*Patent Pending

## Components checklist

- Field wiring for power connections between the lock and power supply or the lock and intelligent system controller (ISC).

If you're powering the lock(s) through the ISC, calculate the total length of the power wire run by summing:

- The distance from the power supply to the ISC.
- The distance from the ISC to the first door.
- If powering more than one door daisy-chained to the same power supply, add the total distance of the power runs between the doors.

If you're powering the lock(s) using a separate power supply, calculate the total length of the power wire run by summing:

- The distance from the power supply to the first door.
- If powering more than one door daisy-chained to the same power supply, add the total distance of the power runs between the doors.

Refer to the table below to determine the minimum wire gauge based on the number of doors sharing the power supply and the total length of the wire run.

<b>Maximum wire length based on no. of doors daisy-chained to power supply</b>				<b>Minimum wire gauge</b>
<b>1 door</b>	<b>2 doors</b>	<b>3 doors</b>	<b>4 doors</b>	
250 feet	125 feet	75 feet	60 feet	18 AWG
400 feet	200 feet	130 feet	100 feet	16 AWG
600 feet	300 feet	185 feet	150 feet	14 AWG

- Field wiring for RS-485 communication connections between the lock and panel interface module (4000 feet maximum):  
Category 5, shielded twisted pair; 24 AWG min.

## Special tools checklist

Use the following checklist to make sure that you have the special tools necessary to install the components provided with your 83KM/93KM–85KM/95KM IDH Max Cylindrical Lock.

- Three (3) to four (4) foot, 3/8" drill bit
- KD303 Drill jig
- T15 TORX® bit driver†

† TORX is a registered trademark of the Camcar Division of Textron.

## Preparing the door and door jamb

### 1 Position template and mark drill points

Note: If the door is a fabricated hollow metal door, determine whether it is properly reinforced to support the lock. If door reinforcement is not adequate, consult the door manufacturer for information on proper reinforcement. For dimensions for preparing metal doors, see the W14 Template—Installation Specifications for 83KM/93KM–85KM/95KM IDH Max Cylindrical Locks.

Note: If the door is a LH or RH door, mark the inside of the door. If the door is a LHRB or RHRB door, mark the outside of the door.

#### For uncut doors and frames

- 1 Measure and mark the horizontal centerline of the knob/lever (the centerline for the chassis hole) on the door and door jamb. Mark the vertical centerline of the door edge.

Note: The recommended height from the floor to the centerline of the lock is 38”.

- 2 Fold the *W16 Template—Installation Template for 83KM/93KM IDH Max Cylindrical Locks* on the dashed line and carefully place it in position on the high side of the door bevel.

Note: For steel frame applications, align the template’s horizontal centerline for the latch with the horizontal centerline of the frame’s strike preparation.

- 3 Tape the template to the door.
- 4 Center punch the necessary drill points. Refer to the instructions on the template.

#### For doors with standard cylindrical preparation

- 1 Fold the *W16 Template—Installation Template for 83KM/93KM IDH Max Cylindrical Locks* on the dashed line. Looking through the hole from the opposite side of the door, align the template so that you see the template outline of the 2 1/8” diameter hole.
- 2 Tape the template to the door.
- 3 Center punch the necessary drill points. Refer to the instructions on the template.

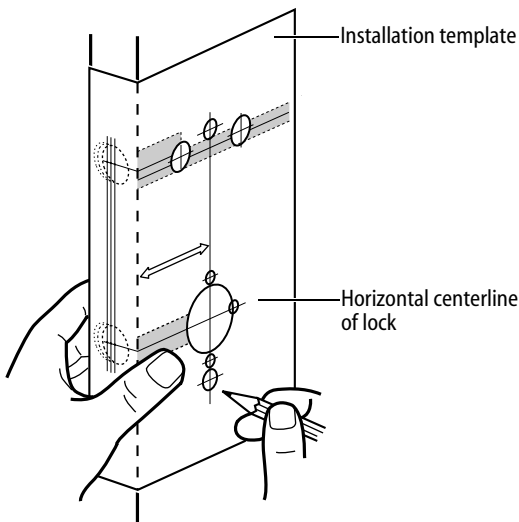

Figure 1 Positioning the template

## Preparing the door and door jamb

### 2 Drill holes and mortise for latch face

- 1 Drill the holes listed below:
  - upper and lower trim holes
    - 5/8" diameter
    - through door
  - door status switch & LH/LHRB reader wire hole
    - 7/8" diameter
    - through door
  - field harness & RH/RHRB reader wire hole
    - 7/8" diameter
    - through door
  - door status switch hole
    - 1" diameter
    - meets door status switch & LH/LHRB reader wire hole
  - solenoid wire hole
    - 3/8" diameter
    - through door
    - before drilling chassis hole**
  - chassis hole
    - 2 1/8" diameter
    - through door
    - after drilling solenoid wire hole
  - latch hole
    - 1" diameter
    - meets chassis hole

Note 1: To locate the center of a hole on the opposite side of the door, drill a pilot hole completely through the door.

Note 2: For holes through the door, it is best to drill halfway from each side of the door to prevent the door from splintering.

- 2 Mortise the edge of the door to fit the latch face.

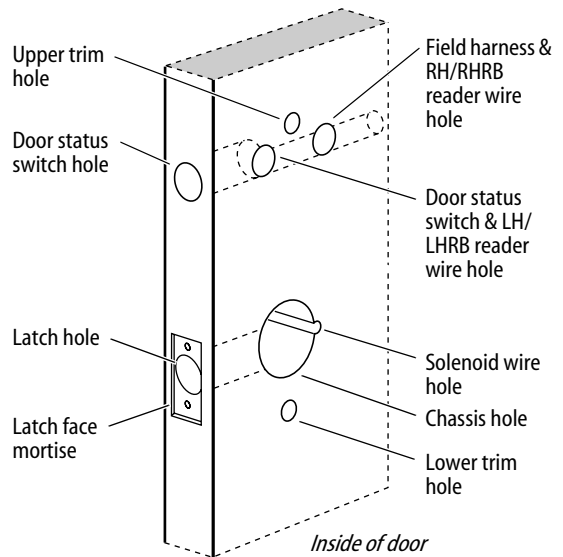

Figure 2 Drilling holes and mortising for the latch face

## Preparing the door and door jamb

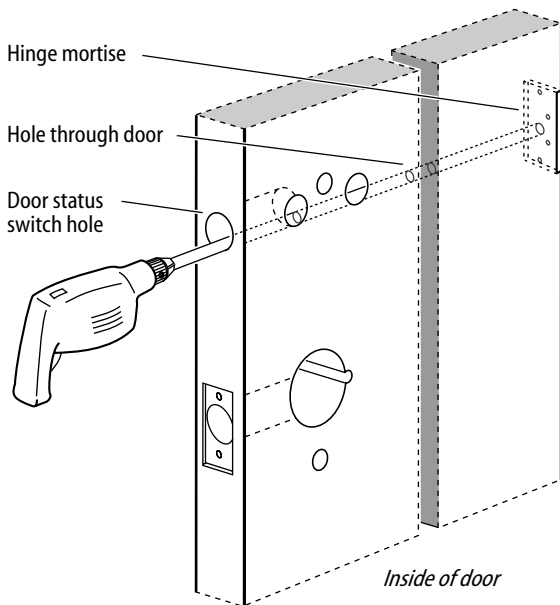

Figure 3 Drilling the hole for the field wire harness

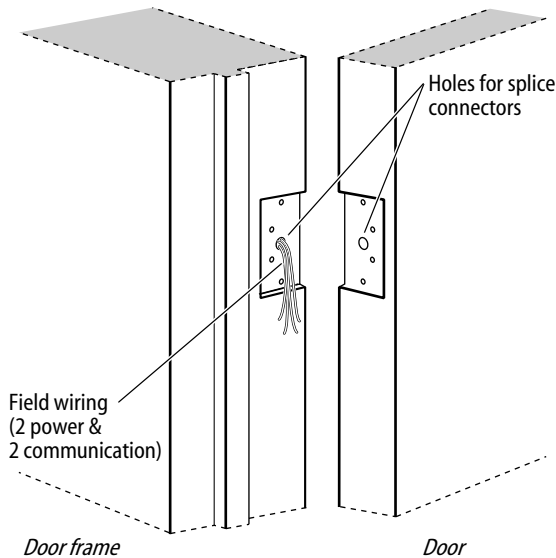

Figure 4 Preparing for the wire transfer hinge

### 3 Drill hole for field wire harness

**Caution 1:** Check with your local fire marshal before drilling a fire-rated door. Drilling through a fire-rated door may void the fire label.

**Caution 2:** Drill carefully through the door, making sure the drill does not break through the face of the door.

- 1 Remove the hinge nearest to the door status switch hole.
- 2 Using a three (3) to four (4) foot drill bit, drill a 3/8" diameter hole through the door, from the bottom of the door status switch hole to the center of the hinge mortise.

Note: It may be easier to drill halfway from each side of the door.

### 4 Prepare for wire transfer hinge and run field wiring

- 1 Drill a wire access hole through the frame side of the hinge mortise.
- 2 Drill holes (or pockets) for the splice connectors in the frame and door. Refer to the hinge manufacturer's specifications for the hole location.
- 3 De-burr the holes to prevent damage to the hinge leads.
- 4 Run the power field wiring from the location for the lock's power supply to the location for the wire transfer hinge.

Note: For an overview of the system, see the figure on page 1. For specifications for power and communication field wiring, see Components checklist, on page 2.

- 5 Run the communication field wiring from the location for the panel interface module to the location for the door transfer hinge.
- 6 Pull the field wiring down the wall and through the access hole in the frame.

## Preparing the door and door jamb

### 5 Install latch

- 1 Install the latch in the door.  
 Note: The latch tube prongs should be centered and should project into the chassis hole.
- 2 Check that the door swings freely.

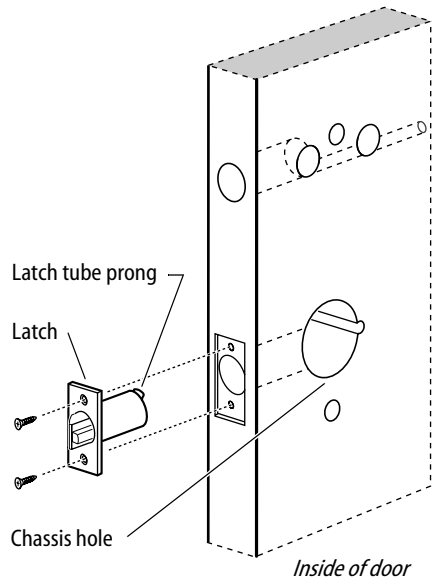

Figure 5 Installing the latch in the door

### 6 Use drill jig to drill through-bolt holes (9KW only)

- 1 Press the drill jig (KD303) onto the door, engaging it with the latch tube prongs. Make sure the front edge of the jig is parallel with the door edge.
- 2 Drill the through-bolt holes (5/16" diameter) halfway into the door.
- 3 Turn the drill jig over and repeat steps 1 and 2 from the opposite side of the door.

Note: Replace the drill jig after 10 door preparations.

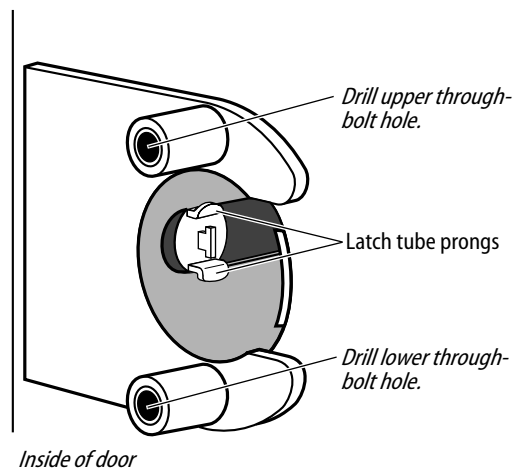

Figure 6 Installing the drill jig and drilling the through-bolt holes

## Preparing the door and door jamb

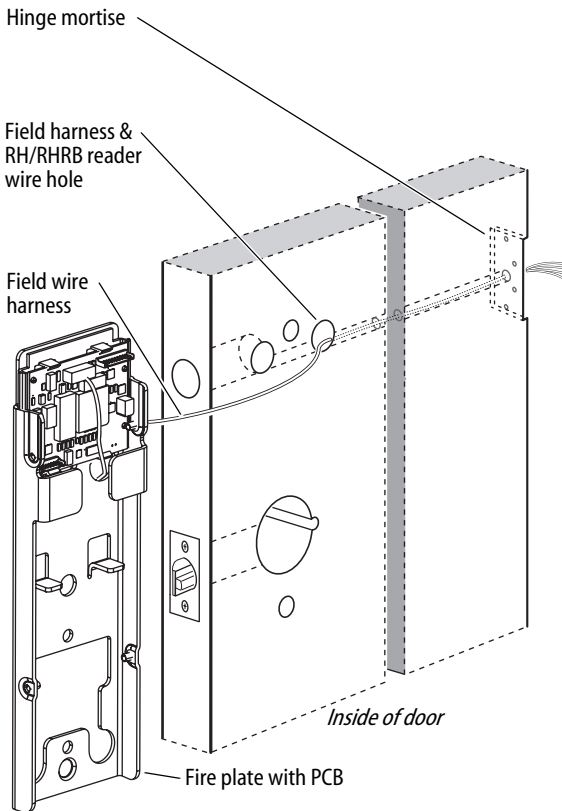

Figure 7 Pulling the field wire harness through the door

### 7 Pull field wire harness through door.

- 1 Route the field wire harness (connected to the PCB) through the wire routing hole in the fire plate and into the hole drilled through the door to the hinge mortise.
- 2 From the latch edge of the door, fish the field wire harness through the door to the hinge mortise.
- 3 Make sure there are 3 to 4 inches of slack in the field wire harness to allow access to the control electronics circuit board in the inside trim.



## Preparing the door and door jamb

### 8 Install door status switch and magnet

- 1 On the door jamb, mark the drill point for the 1" diameter magnet hole. This hole should be directly opposite the door status switch reader wire hole when the door is closed.
- 2 Drill a 1" diameter hole for the magnet, at least 1 3/4" deep.
- 3 Insert the magnet in the hole.
- 4 Insert the door status switch assembly into the door status switch hole in the edge of the door, feeding the connectors out the wire hole to the inside of the door, as shown in Figure 8.

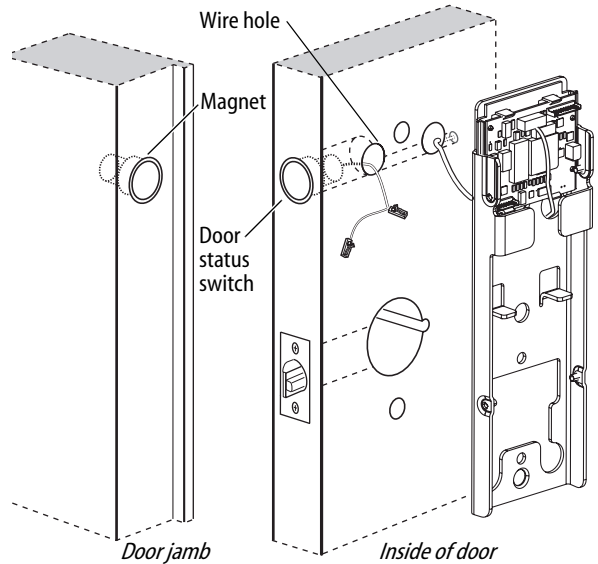

Figure 8 Installing the door status switch and magnet

### 9 Install strike box and strike plate

- 1 In alignment with the center of the latchbolt, mortise the door jamb to fit the strike box and strike plate.
- 2 Insert the strike box and secure the strike with the two screws provided.
- 3 Check the position of the deadlocking plunger against the strike plate.

Caution: The deadlocking plunger of the latchbolt must make contact with the strike plate, as shown in Figure 9b. The plunger deadlocks the latchbolt and prevents someone from forcing the latch open when the door is closed.

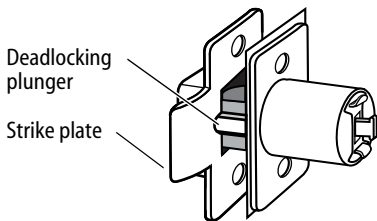

Figure 9b Aligning the deadlocking plunger with the strike plate

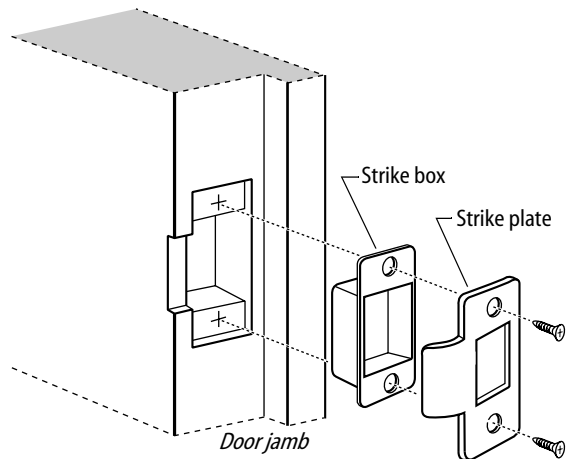

Figure 9a Installing the strike box and strike plate

## Installing the lock & through-bolt trim

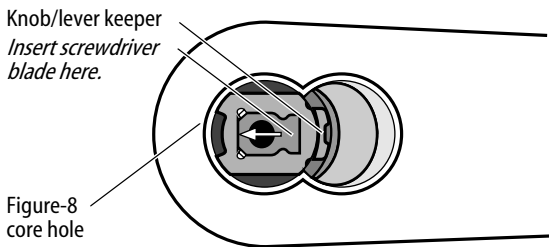

Figure 10 Removing the outside knob/lever

### 10 Remove outside knob/lever

- 1 Insert the control key into the core and rotate the key 15 degrees to the right.
- 2 Insert a flat blade screwdriver into the figure-8 core hole and into the knob/lever.
- 3 Press the screwdriver blade in the direction of the arrow in Figure 10.

Note: You cannot remove the knob/lever if the screwdriver blade is inserted too far past the keeper.

- 4 Slide the knob/lever off of the sleeve.

Caution: Be careful that you do not disconnect the lever keeper spring.

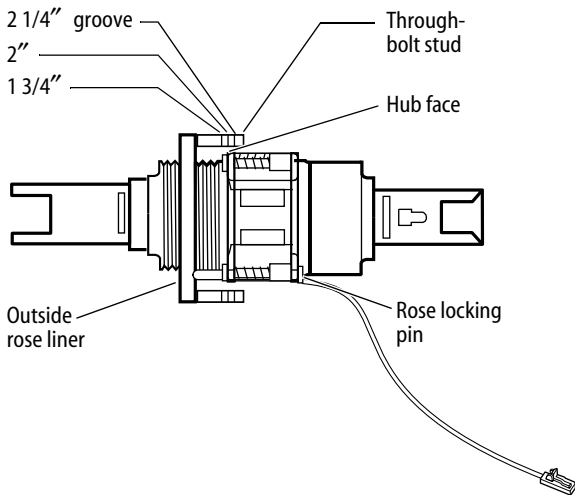

Figure 11 Adjusting the rose liner for the door thickness

### 11 Adjust for door thickness

- 1 Determine the door's thickness.
- 2 Pull the rose locking pin and rotate the outside rose liner until the proper groove on the through-bolt stud lines up with the hub face.

Note 1: Make sure that the locking pin fully locks into the rose liner.

Note 2: The lockset fits doors 1 3/4" to 2 1/4" thick. (A spacer is available for 1 3/8" doors.)

## Installing the lock & through-bolt trim

### 12 Install lock chassis and engage retractor in latch

From the outside of the door, insert the lock chassis into the 2 1/8" chassis hole, routing the solenoid wire through the notch.

Caution: Make sure that the latch tube prongs engage the chassis frame and that the latch tailpiece engages the retractor.

### 13 Install fire plate

Position the fire plate on the inside of the door so that the chassis fits through the square opening in the fire plate, as shown in Figure 13.

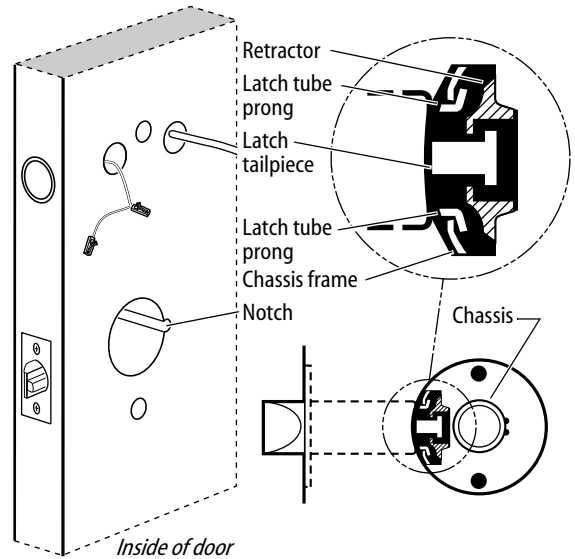

Figure 12 Installing the lock chassis and engaging the retractor in the latch

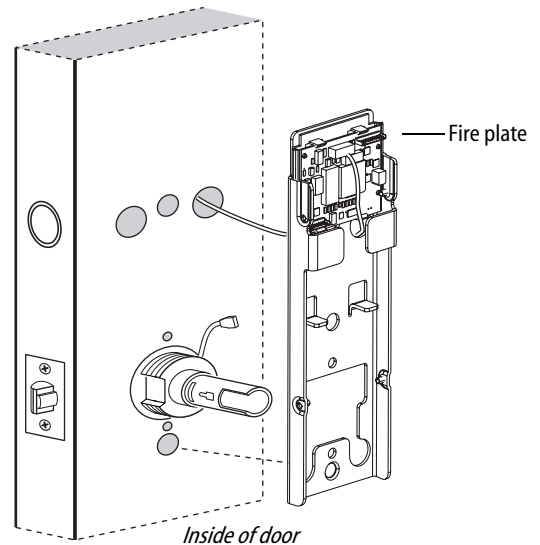

Figure 13 Installing the fire plate

## Installing the lock & through-bolt trim

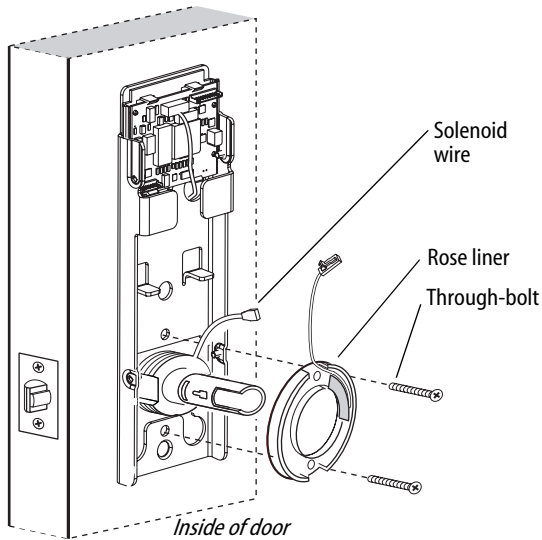

Figure 14 Installing the through-bolts and rose liner (9K shown)

### 14 Install through-bolts and RQE rose liner

- 1 Place the RQE rose liner on the chassis, aligning the holes in the rose liner with the holes prepared in the door.

Caution: Make sure that there is clearance for the solenoid wire between the RQE rose liner and the door.

- 2 Install the through-bolts through the RQE rose liner and door in the top and bottom holes.
- 3 Tighten the RQE rose liner on the door with the through-bolts.

## Installing the lock & through-bolt trim

### 15 Install trim hole insert, bushing, and hub washer

1 Insert the trim hole insert into the upper trim hole on the outside of the door, as shown in Figure 15.

#### 2 For LH and LHRB doors

Insert the bushing into the door status switch & LH/LHRB reader wire hole on the outside of the door, as shown in Figure 15.

#### For RH and RHRB doors

Insert the bushing into the field harness & RH/RHRB reader wire hole on the outside of the door.

3 On each side of the door, slide a hub washer over the chassis sleeve so it rests on the hub.

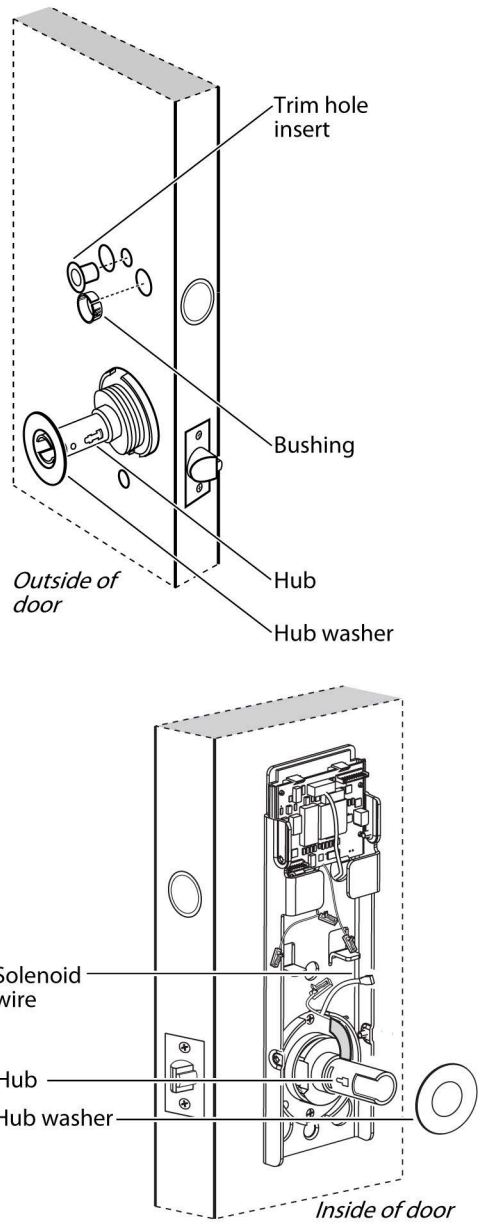

Figure 15 Installing the trim hole insert, bushing, and hub washer

## Installing the lock & through-bolt trim

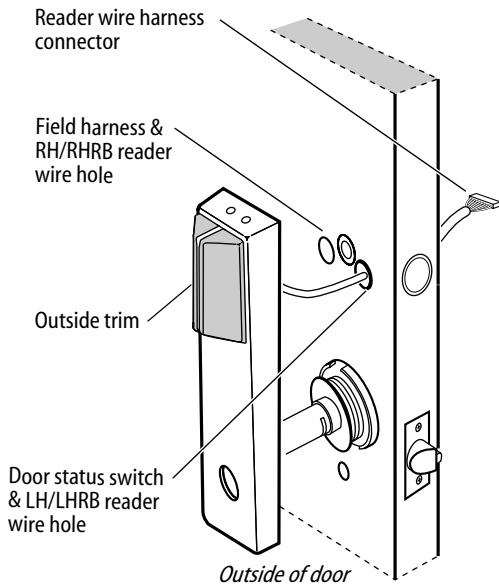

Figure 16a Feeding the reader wire harness connector through the wire hole

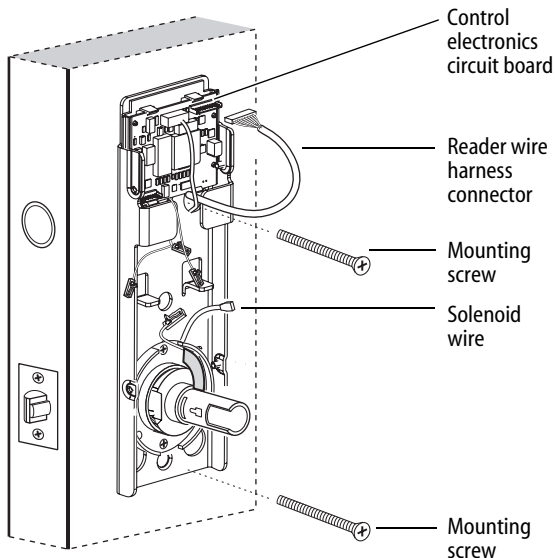

Figure 16b Connecting the reader wire harness to the control electronics circuit board and mounting the fire plate

### 16 Connect reader wire harness

#### 1 For LH and LHRB doors

From the outside of the door, feed the reader wire harness connector through the door status switch & LH/LHRB reader wire hole.

#### For RH and RHRB doors

From the outside of the door, feed the reader wire harness connector through the field harness & RH/RHRB reader wire hole.

Caution: When routing the reader wire harness, make sure the reader wire harness is not routed across any sharp edges or over any surface that could damage its sleeving or wire insulation.

- 2 On the inside of the door insert the two countersunk mounting screws into the holes at the top and bottom of the fire plate.
- 3 Tighten the mounting screw to the outside escutcheon until the fire plate and escutcheon are securely mounted to the door.
- 4 Connect the reader wire harness to the control electronics circuit board in the inside trim.

Caution: When connecting the reader wire harness, make sure:

- there are no loose wire connections where the wires are inserted into the reader wire connector
- **the reader wire harness connector is fully seated in its mating connector on the control electronics circuit board.**

### 17 Set the control electronics board DIP switches

Each IDH Max unit must be addressable (able to be identified automatically by the access control system) with a unique address that matches its OnGuard or Offline G/V Series reader address set up in the management software. See the *System Administration User Guide* for more information on reader addressing.

- 1 On the inside control electronics board use the first five switches to set the reader address in binary code. Switch one is the least significant digit.

## Installing the lock & through-bolt trim

For example, to address an IDH Max Lock with address number 5, the binary equivalent number would be 00101 – OFF OFF ON OFF ON. See table below.

Reader address	(16) Switch 5	(8) Switch 4	(4) Switch 3	(2) Switch 2	(1) Switch 1
0			All off		
1					ON
2				ON	
3				ON	ON
4			ON		
5			ON		ON
6			ON	ON	
7			ON	ON	ON
8	ON				
9	ON				ON
10	ON			ON	
11	ON			ON	ON
12	ON	ON			
13	ON	ON			ON
14	ON	ON	ON		
15	ON	ON	ON	ON	ON
16	ON				
17	ON				ON
18	ON			ON	
19	ON			ON	ON
20	ON		ON		
21	ON		ON		ON
22	ON		ON	ON	
23	ON		ON	ON	ON
24	ON	ON			
25	ON	ON			ON
26	ON	ON		ON	
27	ON	ON		ON	ON
28	ON	ON	ON		
29	ON	ON	ON		ON
30	ON	ON	ON	ON	
31	ON	ON	ON	ON	ON

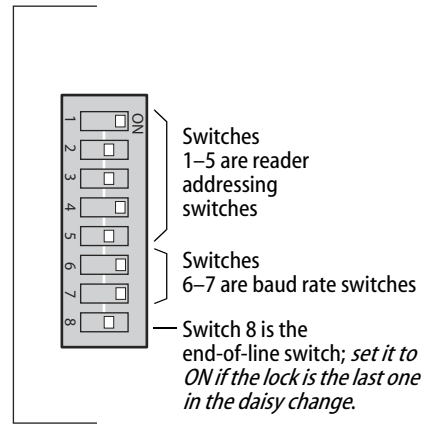

Figure 17 DIP switches on the Control Electronics circuit board set to reader address 5 and 38,400 bps baud rate and not end of line.

## Installing the lock & through-bolt trim

- Use the table below to set both switches 6 and 7 to the baud rate at which the locks will communicate with the intelligent controller.

Baud rate	Switch 6	Switch 7
2,400	All off	
9,600		ON
19,200	ON	
38,400	ON	ON

- For the last IDH Max Lock in the daisy-chain only, set switch 8 to ON. Otherwise, set switch 8 to OFF.

### 18 Complete connections

Caution: When routing the solenoid and sensor wire harness, the sensor wires, and the solenoid wires, make sure the wires are not routed across any sharp edges or over any surface that could damage their sleeving or wire insulation.

- Make the three (3) sensor connections and solenoid connection, and place the wires onto the fire plate.

Wire connection	Color	No. of wires	No. of pins
Solenoid	Yellow	2	3
RQE	Brn/ Org	2	3
Shorting connection	Purple	2	2
Door status sensor	White	2	2

Caution: When making the sensor connections and solenoid connection, make sure:

- **there are no loose wire connections where the wires are inserted into the connectors**
- **the connectors are firmly mated.**



## Installing the lock & through-bolt trim

### 19 Install bottom cover (inside escutcheon)

- 1 **Making sure that the cover does not pinch the wires**, guide the bottom cover over the chassis onto the fire plate.
- 2 Use two cover screws to secure the cover to the side of the fire plate, as shown in Figure 18.

Note: Phillips Type 2 and T20 Torx options are available for the cover mounting screws.

Caution: Dress all wires away from possible pinch points before bottom cover is put in place.

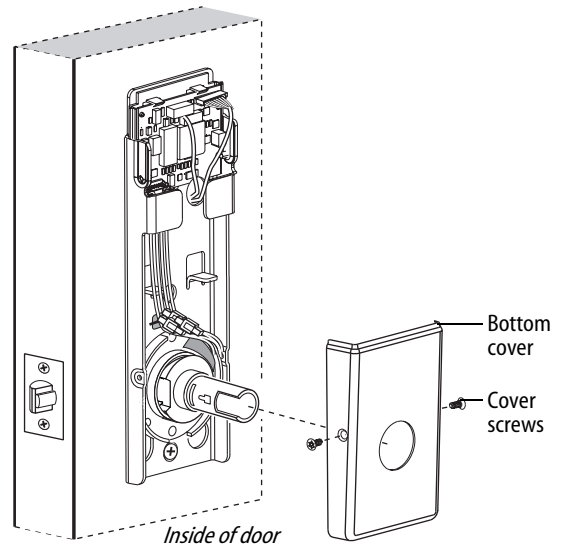

Figure 18 Installing the bottom cover

## Installing the lock & through-bolt trim

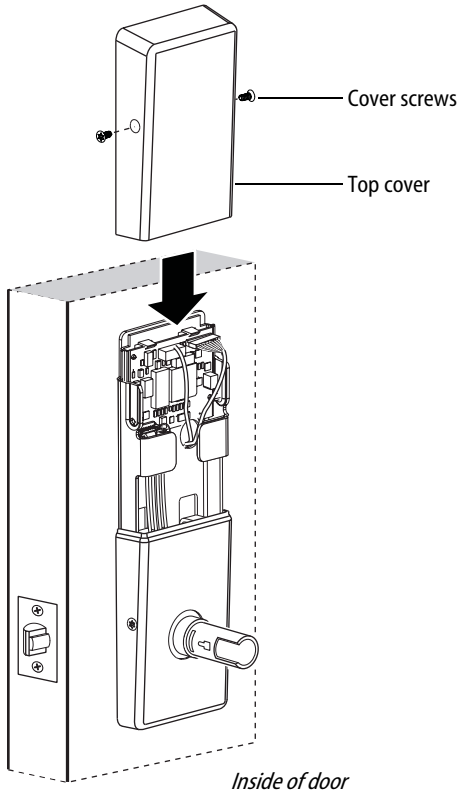

Figure 19 Installing the top cover

### 20 Install top cover (inside escutcheon)

- 1 Position the top cover above the fire plate and slide it down over the guide notches on the fire plate.  
Caution: Make sure that the top cover does not pinch any wires as you slide it over the fire plate.
- 2 Use two cover screws to secure the cover to the side of the fire plate, as shown in Figure 19.

Note: Phillips Type 2 and T20 Torx options are available for the cover mounting screws.

## Installing the lock & through-bolt trim

### 21 Install inside and outside knobs/levers

Note: To use a core and throw member from a manufacturer other than BEST with a 9KW Lock, see the Installation Instructions for 9K Non-interchangeable Cores & Throw Members (T56093). Skip task 22.

- 1 Insert the sleeve bushing into the outside sleeve.  
**Note:** *Sleeve bushing is only required for the 9K lockset.*
- 2 **For the inside and outside knobs.**  
Push firmly on the knob until it is seated.  
**For the inside and outside levers.**  
With the handle pointing toward the door hinges, position the lever on the outside sleeve and push firmly on the lever until it is seated. Repeat, placing the other lever on the inside sleeve.
- 3 Tighten the escutcheon mounting screws.
- 4 Turn the knobs/levers to check that they operate smoothly.

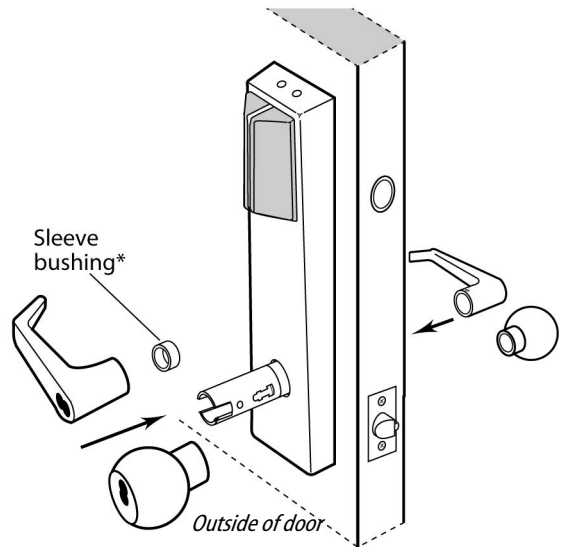

Figure 20 Installing the knobs/levers

### 22 Install core and throw member

- 1 Install the throw member into the back of the core.
- 2 Insert the control key into the core and rotate the key 15 degrees to the right.

**Caution:** You must use the blocking plate when installing an 8K lockset to prevent unauthorized access.

**For 6-pin core users only:** Install the plastic spacer (not shown, supplied with permanent cores).

- 3 Insert the core and throw member into the lever with the control key.
- 4 Rotate the control key 15 degrees to the left and withdraw the key.

**Caution:** The control key can be used to remove cores and to access doors. Provide adequate security for the control key.

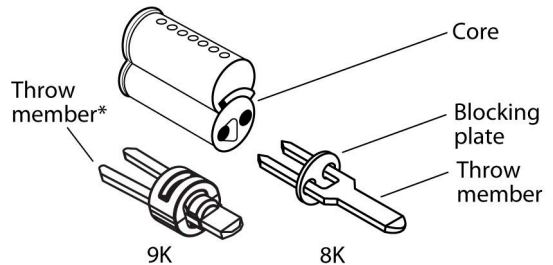

Figure 21a Installing the blocking plate and throw member

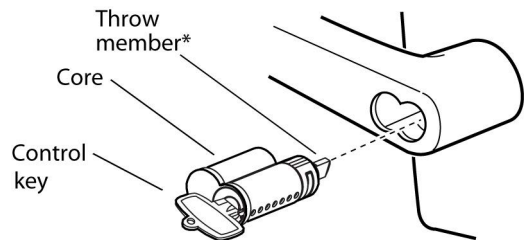

Figure 21b Installing the core

\*Patent Pending

## Installing the lock & through-bolt trim

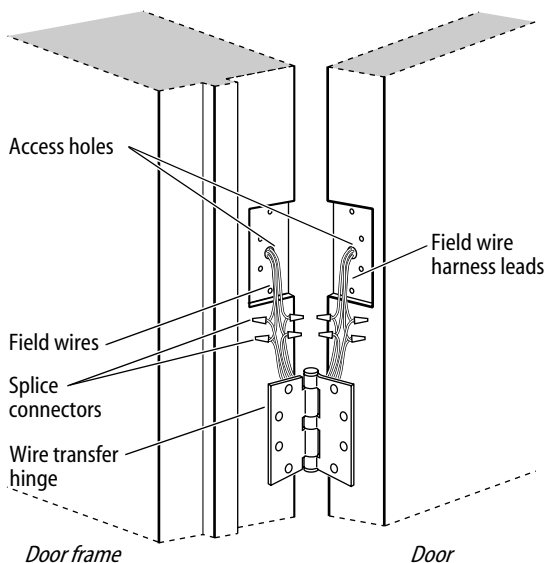

Figure 22 Installing the wire transfer hinge

### 23 Install wire transfer hinge

- 1 Trim the four wires of the field wire harness, which you pulled through the hinge edge of the door in Task 7. Leave sufficient length to connect to the wire transfer hinge.
- 2 Splice the power and communication field wiring to the four pairs of leads on the frame side of the hinge, following the hinge manufacturer's instructions.
- 3 Splice the four field harness wires (listed in the table below) to the four pairs of leads on the door side of the hinge, matching each pair of leads to its corresponding field wire.

Wire	Color
Ground	Black
12 VDC	Red
Com+	Orange
Com-	Green

- 4 Insert the wires and splice connectors into the holes or pockets in the door and frame, being careful not to pinch the wires. Install the wire transfer hinge.

### 24 Optional: Install lock power supply

If you are providing a separate power supply for the lock instead of providing power via the panel interface module, connect the two power field wires (run from the wire transfer hinge) to the power supply. Make sure power (12 volts DC) and ground are connected properly.

Follow the instructions provided by the power supply manufacturer. Do not plug in the power supply yet.

Note: For specifications for the power supply, see Components checklist, on page 2.

## Testing the installation

### 25 Connect to the BAS-500 or BAS-1000 access control panels

- 1 If necessary daisy-chain all IDH Max Locks by splicing like wires and make all necessary wire runs to either a BAS-500 or BAS-1000 panel.

**Note:** A BAS-500 panel will accept up to 16 IDH Max 1300 locks and a BAS-1000 panel will accept up to 32 IDH Max 1300 locks.

- 2 Connect the orange wire or its extension to the RS485 connection TR2+ or higher. See Figure 23.
- 3 Connect the green wire or its extension to the RS485 connection TR2- or higher.
- 4 Connect the shield strand to the RS485 connection GND (ground).

### 26 Test the installation

After downloading panel information to the IDH Max 1300 Locks, perform the following steps to test the installation. Also, perform any standard testing recommended by the manufacturer of the access control panel. If you encounter problems, see *Troubleshooting the installation*, on page 22.

- 1 Check the control electronics' red status LED.  
Both LEDs should be blinking red, indicating that the communication connection between the access control panel and the lock's control electronics circuit board is OK.
- 2 After performing any necessary programming for the lock and putting the door in a locked mode, use a valid token to access the lock.

Confirm that the red reader LED, green reader LED, and sounder respond as expected.

The lock should allow access, verifying that the solenoid is working.

To check that the reader is working, view the lock's event history and verify that the information recorded for the token is correct.

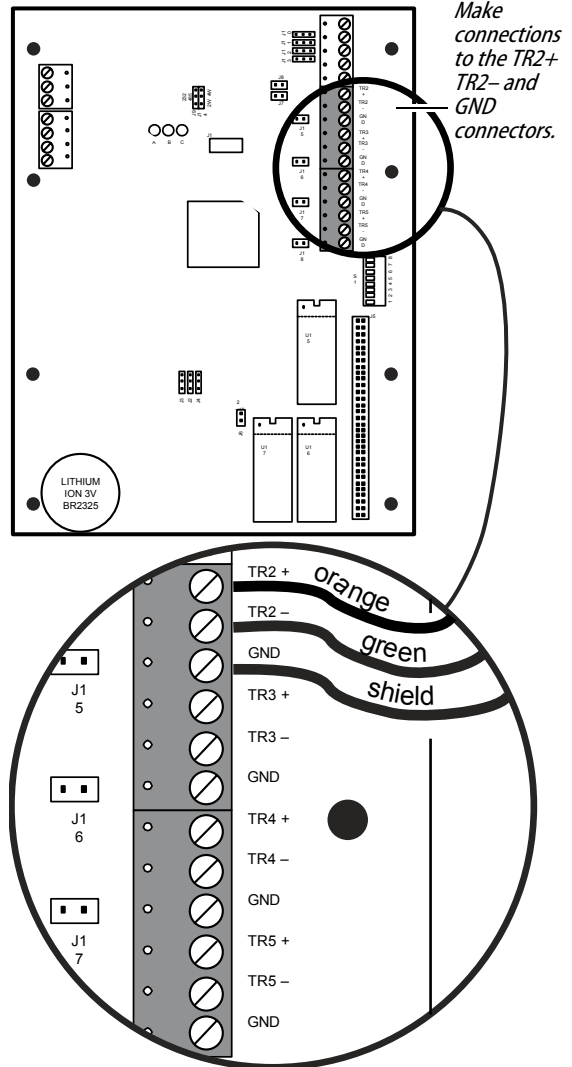

Figure 23 Making connections to the access control panel, BAS-1000 shown.

## Troubleshooting the installation

- 3 Use an invalid token to attempt to access the lock.  
Confirm that the red reader LED, green reader LED, and sounder respond as expected.  
The lock should deny access.
- 4 With the door armed, attempt to exit through the door.  
The request-to-exit (RQE) feature should let you exit without triggering an alarm by the access control panel.
- 5 Remove power from the lock and check whether the door remains locked or is unlocked.  
Verify that the lock fails safe or secure, according to its function.
- 6 With the door armed, hold the door open. Hold a magnet against the edge of the door, over the door status sensor, until the access control panel sees the door as closed. Then remove the magnet.  
Verify that the appropriate alarm response is triggered by the access control panel, indicating that the door status sensor is working.

To troubleshoot installation problems, refer to the table below. For more information, refer to the *IDH Max Lock Service Manual* (T60775) and to the documentation provided by the manufacturer of the access control panel/reader interface.

You notice . . .	Possible causes include . . .	You should . . .
Control electronics' red status LED and access control panel's red status LED are on only 20% of the time.	Communication between the lock's control electronics circuit board and the access control panel has been interrupted.	<p>Make sure DIP switches 6 and 7 on the lock's control electronics circuit board are set to the proper baud rate. See page 16.</p> <p>Check the connections for all communication field wiring.</p> <p>Make sure that the last daisy-chained IDH Max DIP switch is set to ON and all others are OFF. See page 16.</p> <p>Check the communication connections between the field wire harness and the wire transfer hinge.</p>
Control electronics' red status LED is off.	Power is not being supplied to the lock.	<p>Make sure that the lock's power supply is connected to electrical service.</p> <p>Check the connections for all power field wiring to the lock.</p> <p>Check the power connections between the field wire harness and the wire transfer hinge.</p>





**For assistance or warranty information:**  
Call 1-800-392-5209 or visit  
<https://dhw.support.dormakaba.com/hc/en-us>

**Warning:** This Manufacturer advises that no lock can provide complete security by itself. This lock may be defeated by force or technical means, or evaded by entry elsewhere on the property. No lock can substitute for caution, awareness of your environment, and common sense. Builder's hardware is available in multiple performance grades to suit the application. In order to enhance security and reduce risk, you should consult a qualified locksmith or other security professional.



**Si desea ayuda o información sobre la garantía:**  
llame al 1-800-392-5209 o visite  
<https://dhw.support.dormakaba.com/hc/en-us>

**Advertencia:** Este fabricante hace saber que no hay cerraduras que puedan proporcionar seguridad completa por sí mismas. Esta cerradura puede fallar forzada o utilizando medios técnicos o entrando por otra parte del edificio. No hay cerraduras que puedan sustituir precaución, estar al tanto de su entorno y sentido común. Este fabricante también ofrece cerraduras de diferentes grados y rendimientos para ajustarse a su aplicación. Para mejorar la seguridad y reducir riesgos, usted debe consultar con un cerrajero especializado u otro profesional de seguridad.



**Pour de l'aide ou des informations sur la garantie:**  
Veuillez appeler le 1-800-392-5209 ou visiter  
<https://dhw.support.dormakaba.com/hc/en-us>

**Advertissement:** Le fabricant tient à vous aviser qu'aucun verrou ne peut à lui seul offrir une sécurité complète. Ce verrou peut être malhonnêtement forcé par la force ou des moyens techniques ou être évité par l'utilisation d'une autre entrée sur la propriété. Aucun verrou ne peut remplacer la surveillance de votre environnement et le bon sens. La qualification pour le constructeur est offerte selon différents grades de performance pour différentes applications. Afin d'augmenter la sécurité et de réduire le risque, vous devez consulter un serrurier qualifié ou un autre professionnel de la sécurité.