

HD8000 DS/DST X FTHD

Heavy duty parallel arm door saver
with flush transom bracket

Installation Instructions

OVERVIEW

Surface closer components

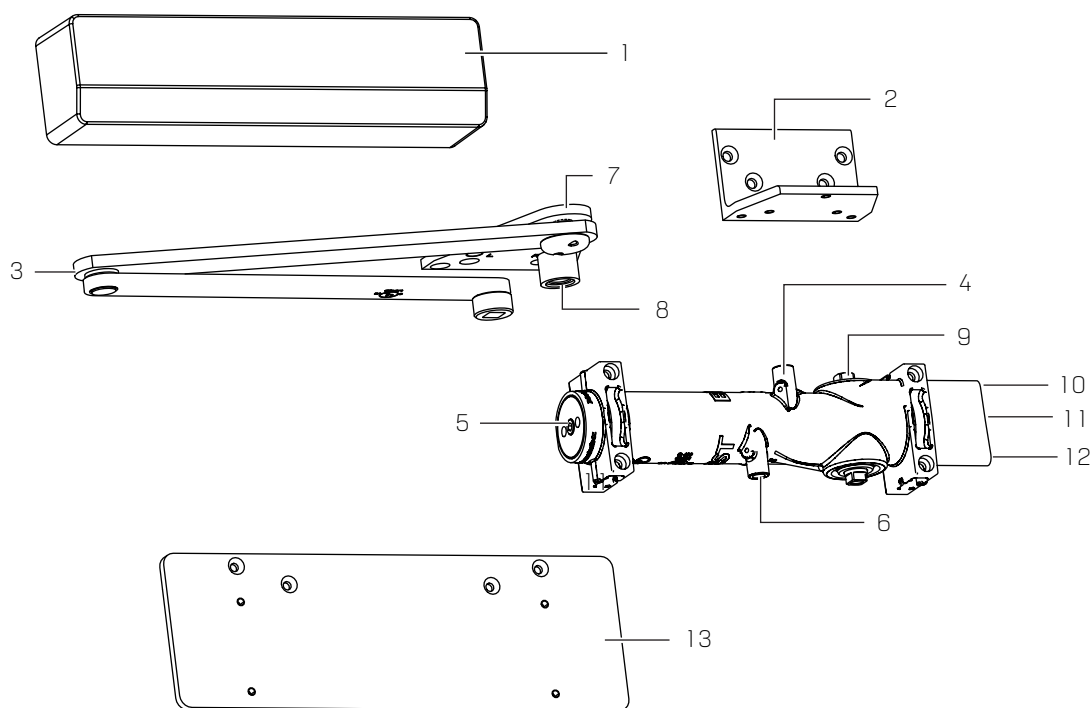

1 Full cover (standard)

2 Flush transom bracket

3 Door saver arm

4 Advanced variable backcheck

5 Spring force adjustment

6 Backcheck adjustment

7 Soffit plate

8 Bumper stop

9 Pinion

10 Delayed action adjustment

11 Sweep speed adjustment

12 Latch speed adjustment

13 Drop plate (optional)

Table of contents

1	Technical specifications	3
1.1	Overview	3
1.2	Tools recommended	3
1.3	Handing the door	3
2	Instructions - parallel mount	4
2.1	Installing drop plate and surface closer	4
2.2	Installing flush transom bracket	4
2.3	Securing main arm	5
2.4	Optional hold open	6
3	Adjustments	6
3.1	Adjust closing speeds: sweep, latch, backcheck, delayed action	6
3.2	Adjust spring force	7
4	Install covers	8

1 Technical specifications

1.1 Overview



Sex nuts are required for attachment of components to unreinforced doors and to wood or plastic faced composite type fire doors, unless an alternative method is identified in the individual door manufacturer's listings.



Maximum door opening degree is 110°.



Hold open range is from 85° to 110° with optional hold open kit.



Know the swing of the door which is being installed prior to installation.



Verify closer spring size prior to installation.



Make sure door efficiently operates prior to installing closer.



Do not hammer arm onto spindle. Warranty will be void.

1.2 Tools recommended

Table 1

Drill bits:	#3 Phillips screwdriver
Metal: 1 3/64" or #7 drill bit; 1/4-20 tap	3/16" flat head screwdriver
Wood: 5/32" bit	5mm hex key
1/2" box wrench	

1.3 Handing the door

Fig.1

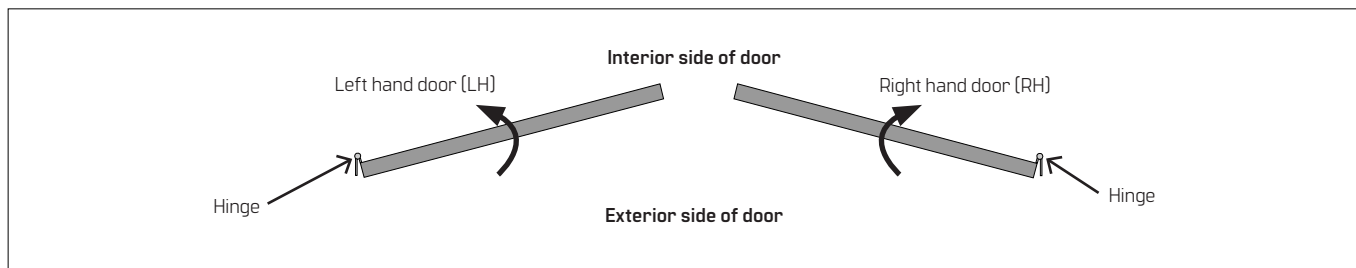

2 Instructions - parallel mount

2.1 Installing drop plate and surface closer

Fig.2

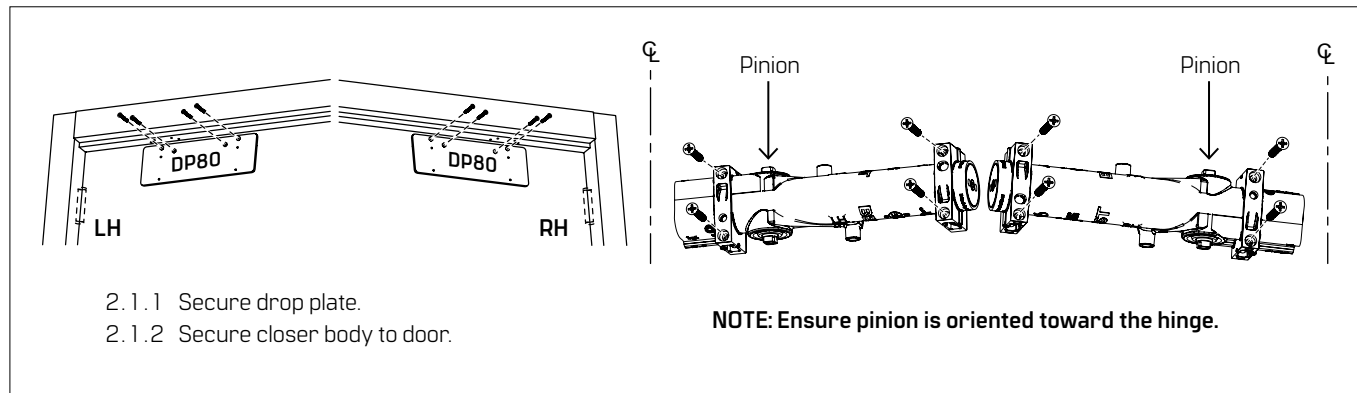

2.2 Installing flush transom bracket

Fig.3

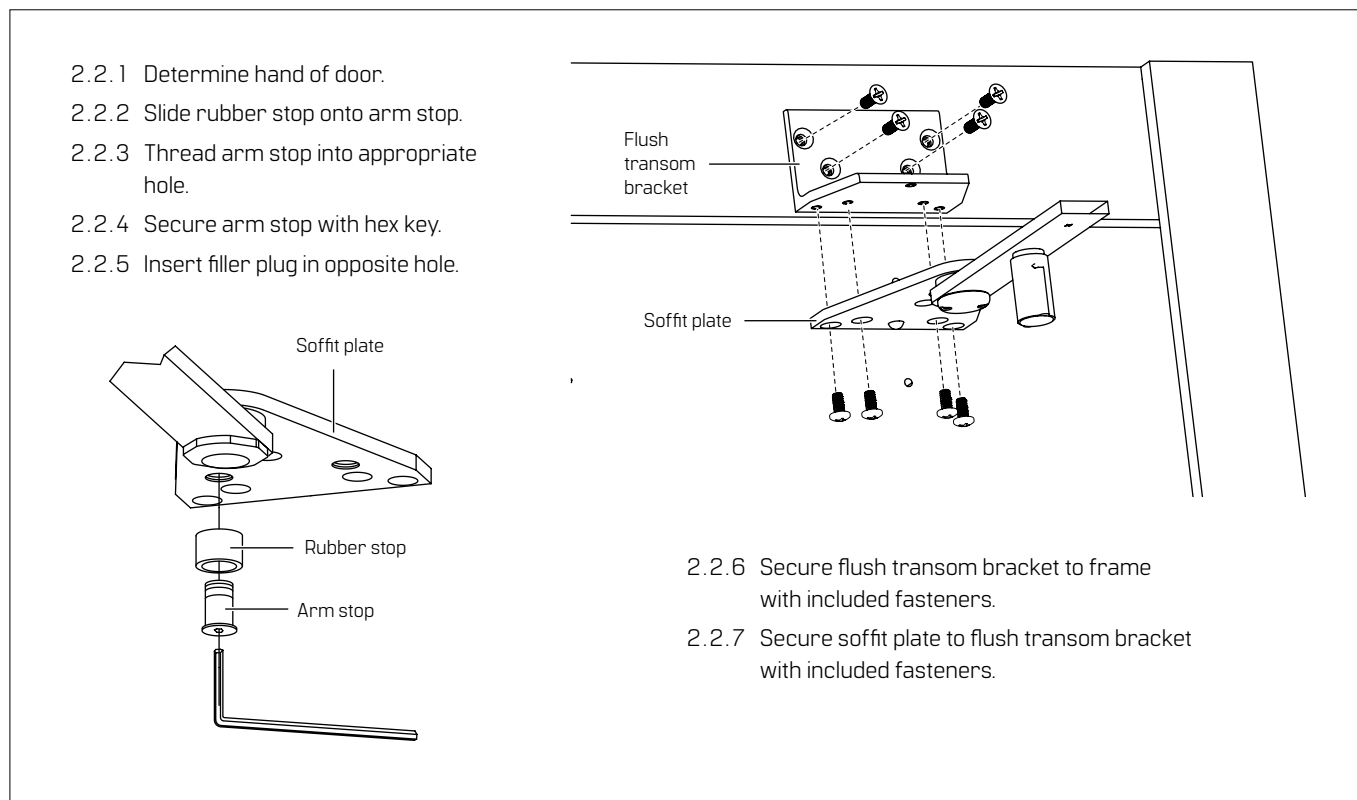

2.3 Securing main arm

Fig.4



Do not hammer arm onto spindle. Warranty will be void.

2.3.1 Preload arm by placing wrench on bottom pinion.

View from top of door

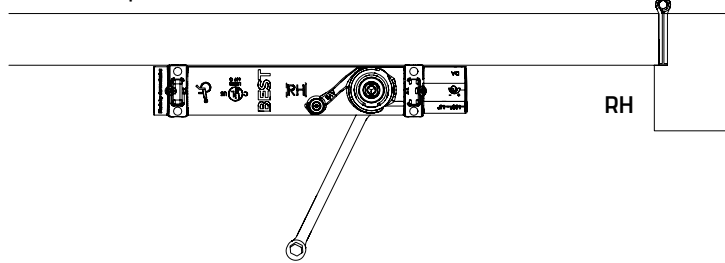

2.3.2 Rotate wrench 45° TOWARD hinge edge of door.

View from top of door

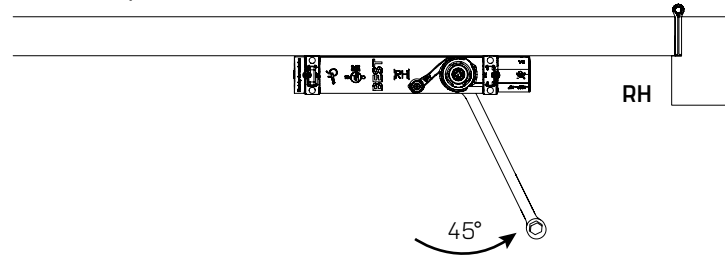

2.3.3 With main arm parallel to door, place main arm onto top pinion.

View from top of door

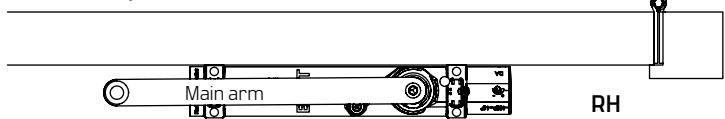

2.3.4 Secure arm to closer with pinion screw.

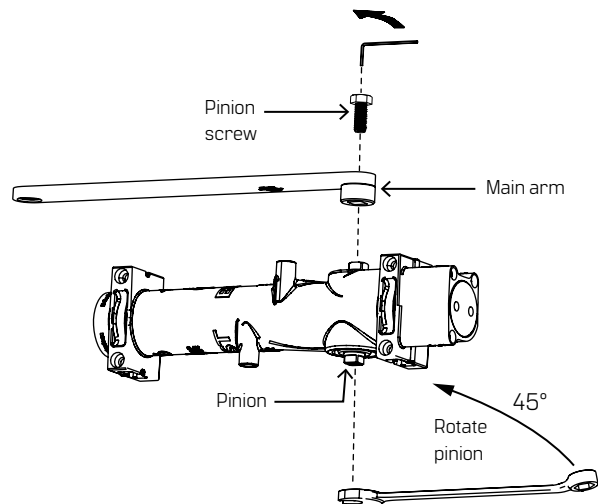

2.4 Optional hold open

Fig.5

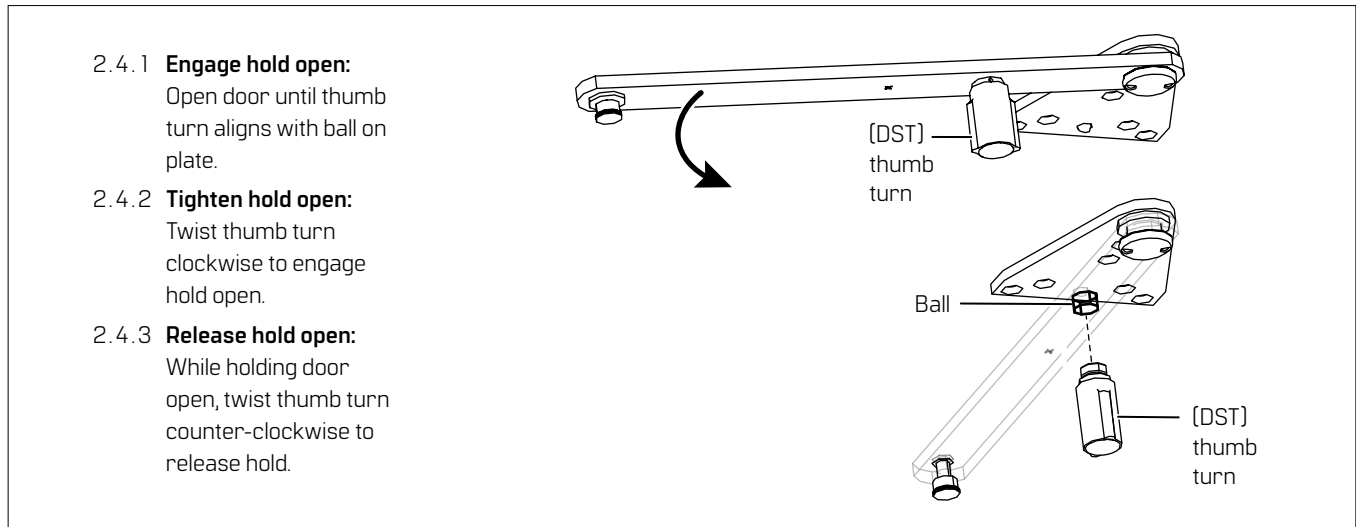

3 Adjustments



Confirm closer spring size prior to making any closing speed adjustments.



Do not back valve heads out beyond closer casting.



Maximum opening angle is 110°.



Door should close in 3 to 6 seconds from 90°.



Do not close valves completely.

3.1 Adjust closing speeds: sweep, latch, backcheck, delayed action

Fig.6

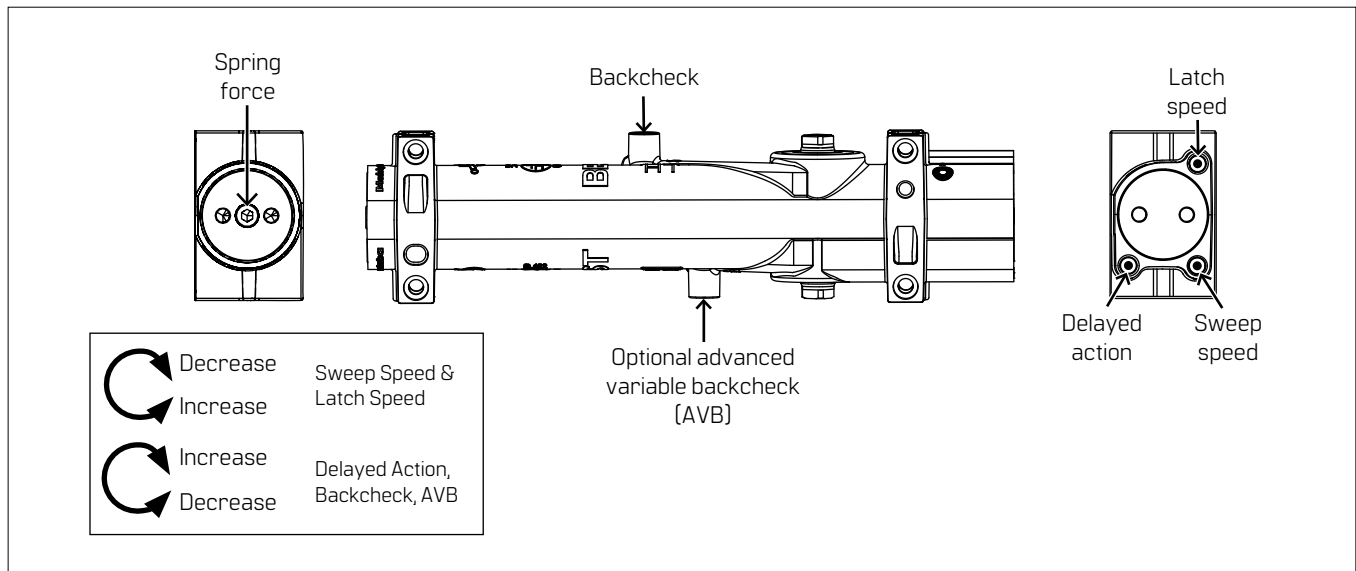

3.1.1 Adjust **closing sweep speed**: 90° to start of latch speed.

- Increase sweep speed: Turn valve counter-clockwise.
- Decrease sweep speed: Turn valve clockwise.

3.1.2 Adjust **closing latch speed**: 15° to close.

- Increase latch speed: Turn valve counter-clockwise.
- Decrease latch speed: Turn valve clockwise.

3.1.3 Adjust **opening backcheck**: beginning at 50°.

- Increase resistance: Turn valve clockwise.
- Decrease resistance: Turn valve counter-clockwise.

3.1.4 Adjust **closing delayed action**: beginning at 110°.

- Increase delayed action: Turn valve clockwise.
- Decrease delayed action: Turn valve counter-clockwise.

3.2 Adjust spring force

Fig.7

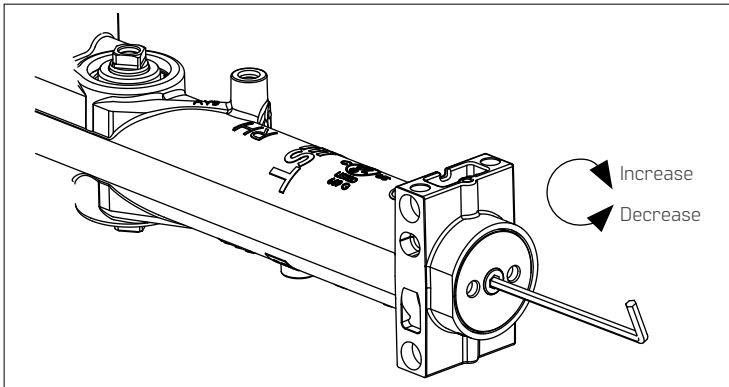

HD 8 0 1 6 - supplied with a size 4

HD 8 0 5 6 - supplied with a size 6

HD 8 0 1 6 ONLY - Barrier free openings: Take an opening force reading from the pull on the door. If required, adjust the spring force to meet the barrier-free requirement.

Depending on opening conditions, a door adjusted to meet barrier-free forces may not have sufficient power to reliably close and latch the door.

Parallel mount					
	Closer size	Max door weight (lbs)	Door width		Full turns
			Interior	Exterior	
HD 8 0 1 6	3	100	2'6"	----	-1 2
	4	125	3'	2'6"	0
	5	150	3'6"	3'	+4
	6	200	4'	3'6"	+1 2
HD 8 0 5 6	5	150	3'6"	3'	-6
	6	200	4'	3'6"	0
	6+	250	---	4'	6+

4 Install covers

Fig.8

- 4.1.1 Place tab in cover slot, opposite main arm.
- 4.1.2 Place cover over closer and snap into place.

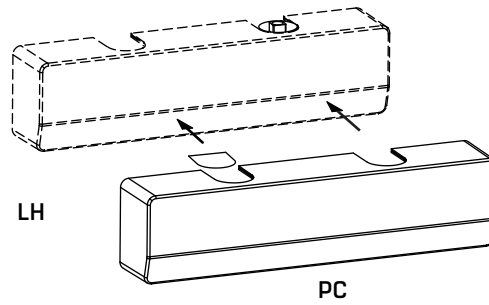

For online instructions visit:

<https://dhwsupport.dormakaba.com/hc/en-us>

For assistance or warranty information:

Call 1-800-392-5209 or visit

<https://dhwsupport.dormakaba.com/hc/en-us>