

HD7016 ARNP/ARNPJ/ARNPP

Round arm for regular, top jamb, parallel mounts with narrow profiles

Installation Instructions

OVERVIEW

- 1** Door closer
- 2** Main arm
- 3** Connecting arm (flat)
- 4** Bar and shoe
- 5** Dust cap
- 6** Flat head combo screws
- 7** Pan head combo screws
- 8** Pinion screw
- 9** PA bracket
- 10** PA shoe screws

AR Regular mount

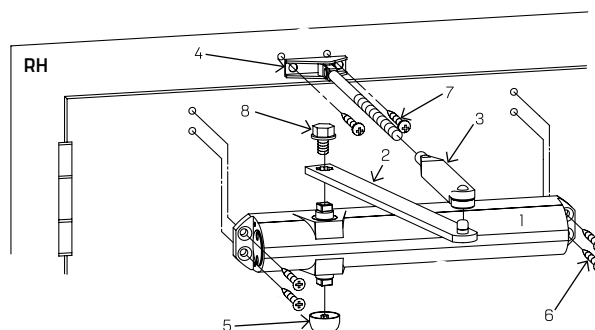

AR Top jamb mount

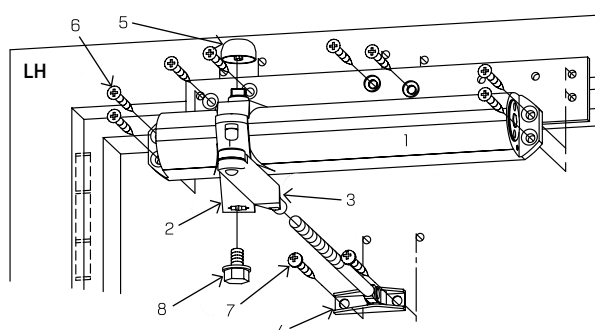

AR Parallel mount

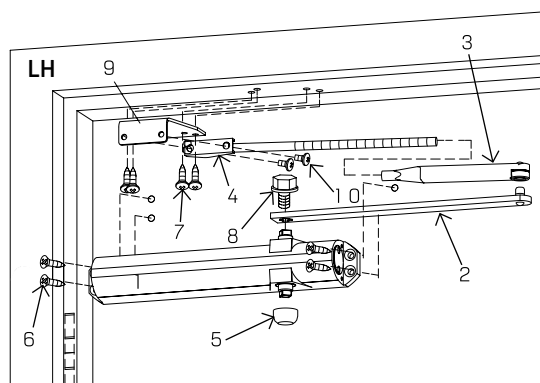

Table of contents

1	Technical specifications	3
1.1	Overview	3
1.2	Tools recommended	3
1.3	Handing the door	3
2	Instructions - AR regular mount	4
2.1	Closer system: Round arm (AR)	4
2.2	Installing (optional) backplate and surface closer	4
2.3	Installing the arm	4
3	Instructions - AR top jamb mount	5
3.1	Closer system: Round arm (AR)	5
3.2	Installing (optional) plate and surface closer	5
3.3	Installing the arm	5
4	Instructions - AR parallel mount	6
4.1	Closer system: Round arm (AR)	6
4.2	Installing drop plate and closer	6
4.3	Installing parallel bracket and arm	6
5	Adjustments	7
5.1	Adjust closing speeds: sweep, latch, backcheck, delayed action	7
5.2	Adjust spring force	8
6	Install covers	8

1 Technical specifications

1.1 Overview



Sex nuts are required for attachment of components to unreinforced doors and to wood or plastic faced composite type fire doors, unless an alternative method is identified in the individual door manufacturer's listings.



Maximum door opening degree is 180°.



Know the swing of the door which is being installed prior to installation.



Verify closer spring size prior to installation.



Make sure door efficiently operates prior to installing closer.



Do not hammer arm onto spindle. Warranty will be void.

1.2 Tools recommended

Table 1

Drill bits:	#3 Phillips screwdriver
Metal: 7/32" drill bit; 1/4-20 tap	3/16" flat head screwdriver
Wood: 3/8" and 5/32" bit	5mm hex key
1/2" box wrench	

1.3 Handing the door

Fig. 1

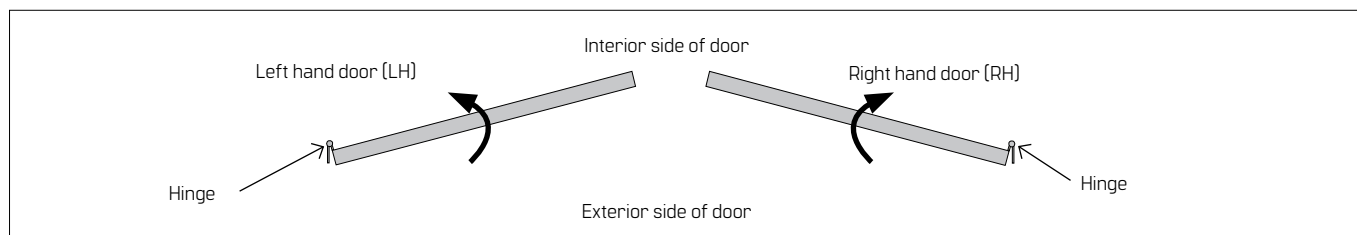

2 Instructions - AR regular mount

2.1 Closer system: Round arm (AR)

Fig.2

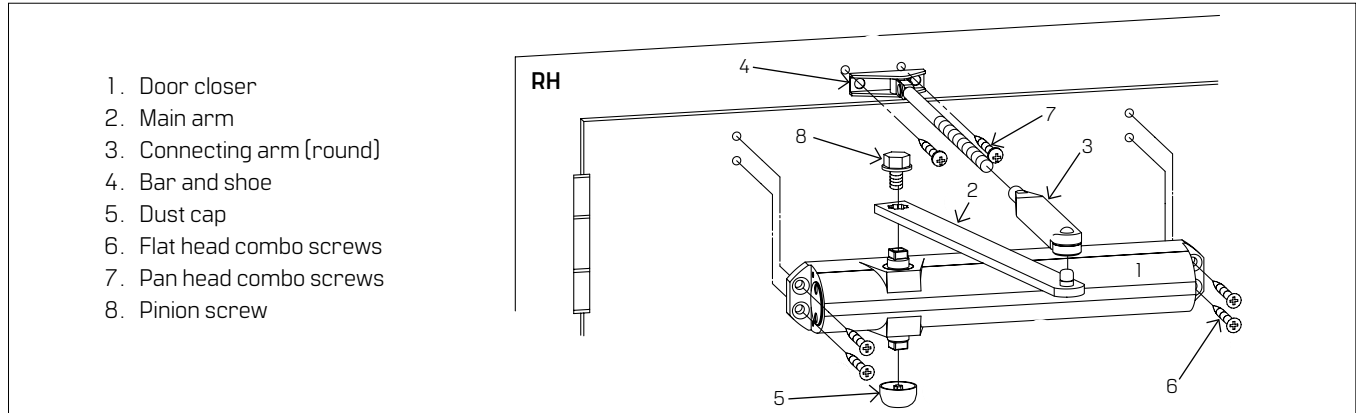

2.2 Installing backplate (optional) and surface closer

Fig.3

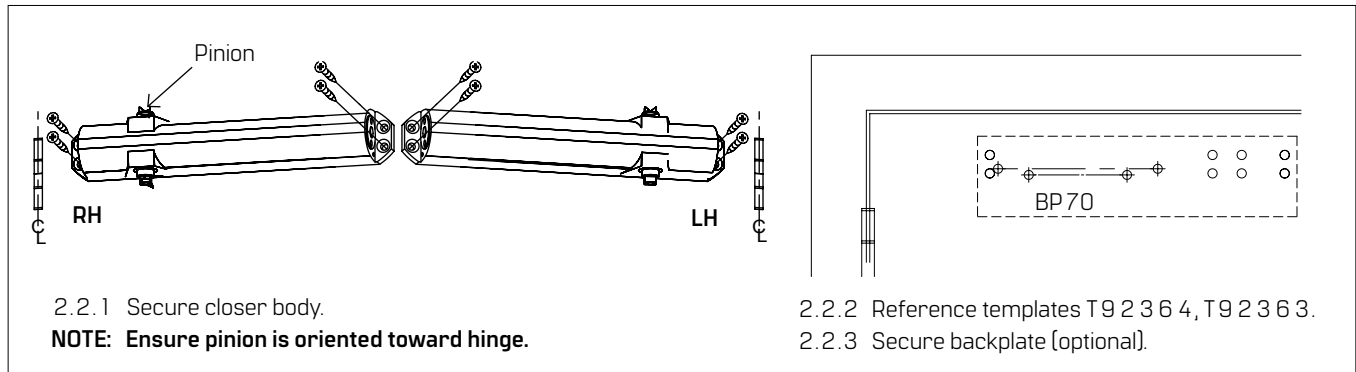

2.3 Installing the arm

Fig.4

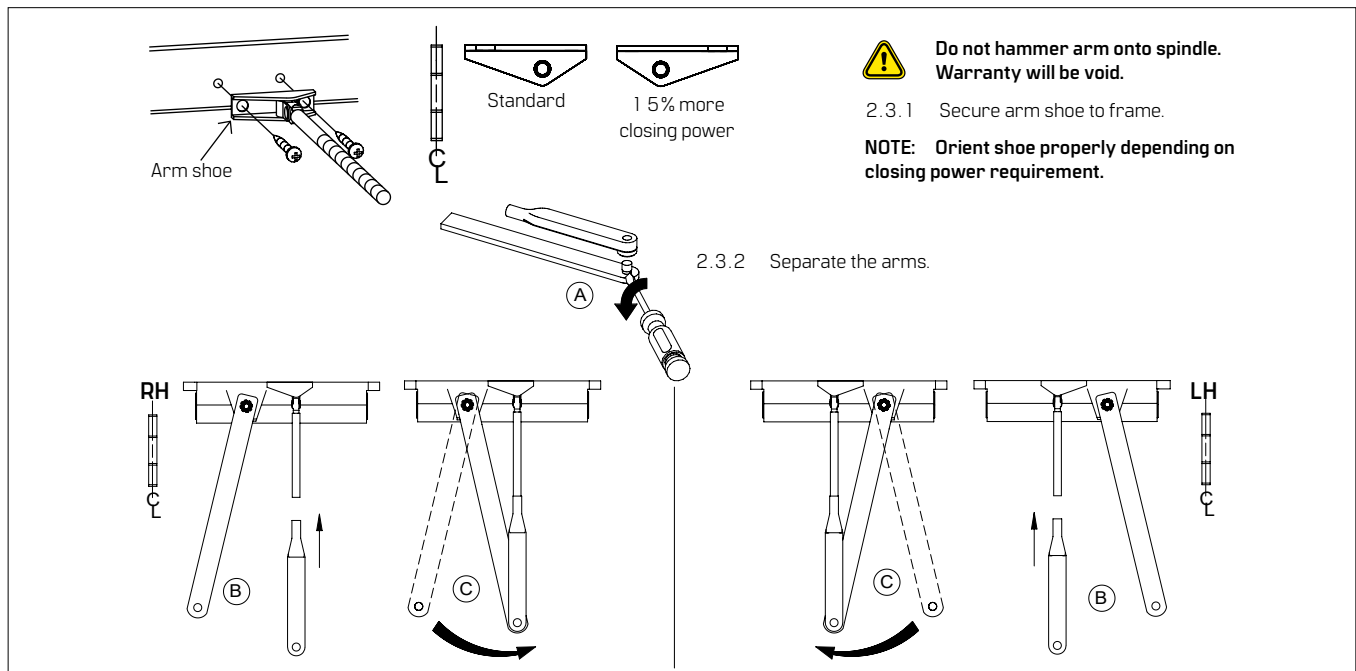

3 Instructions - AR top jamb mount

3.1 Closer system: Round arm (AR)

Fig.5

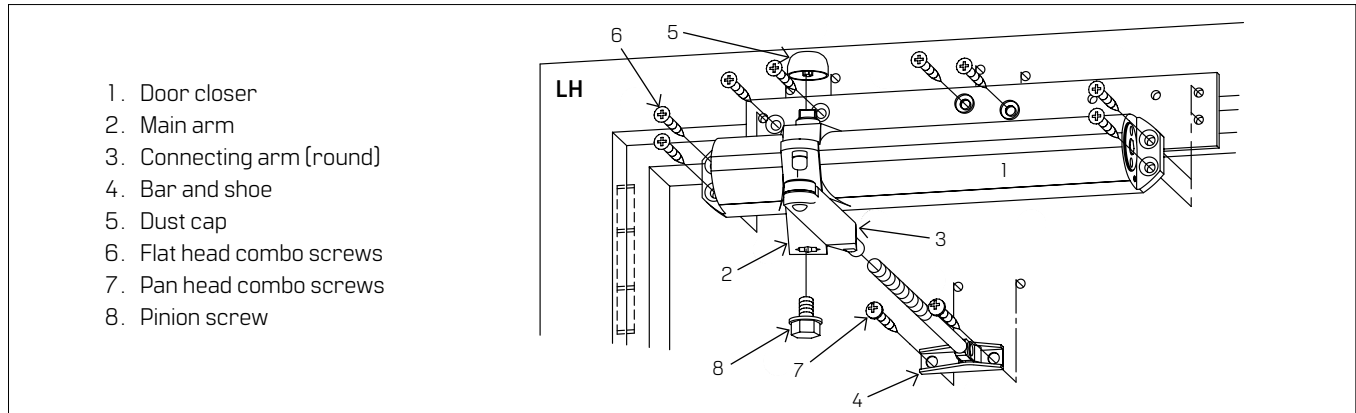

3.2 Installing plate (optional) and surface closer

Fig.6

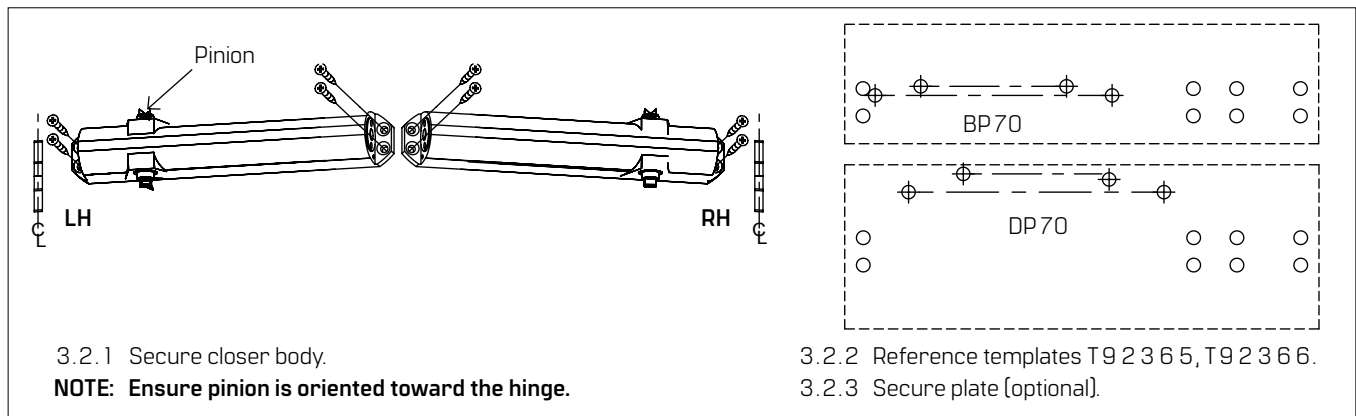

3.3 Installing the arm

Fig.7

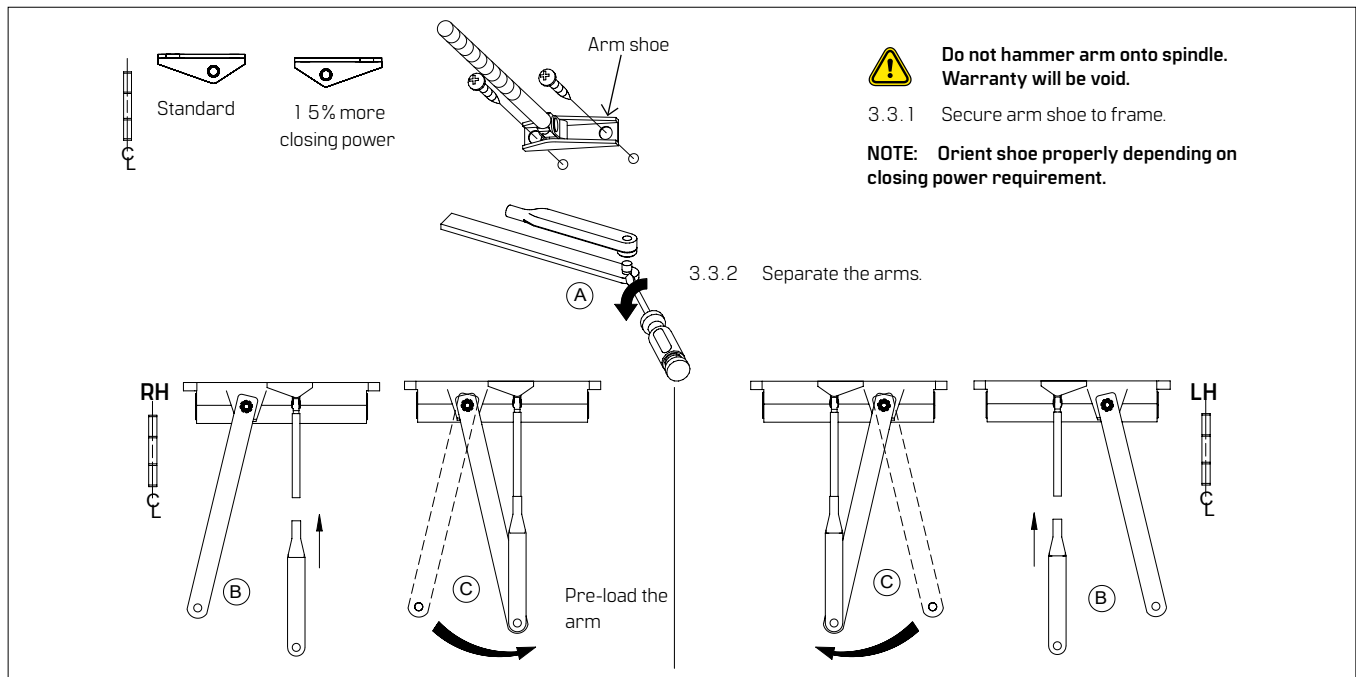

4 Instructions - AR parallel mount

4.1 Closer system: Round arm (AR)

Fig.8

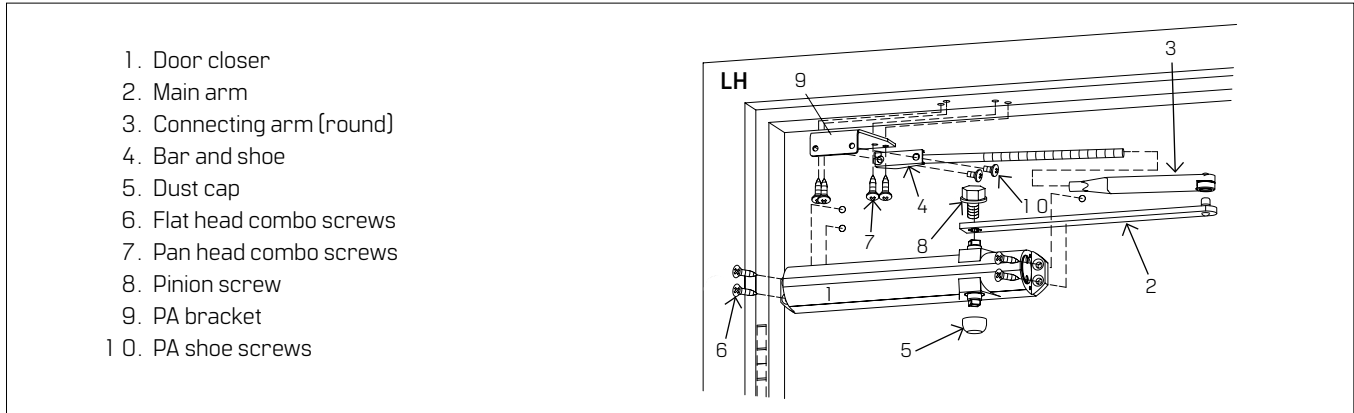

4.2 Installing drop plate and closer

Fig.9

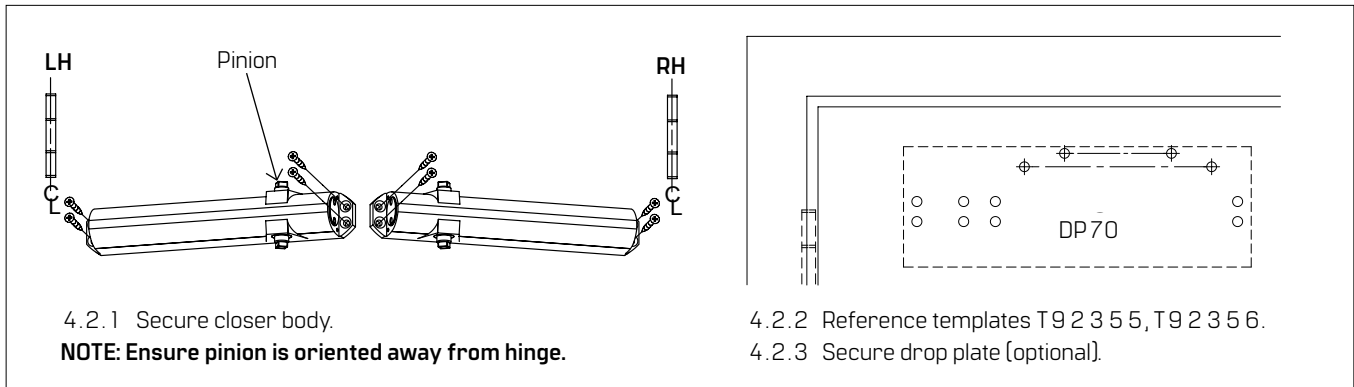

4.3 Installing parallel bracket and arm

Fig.10

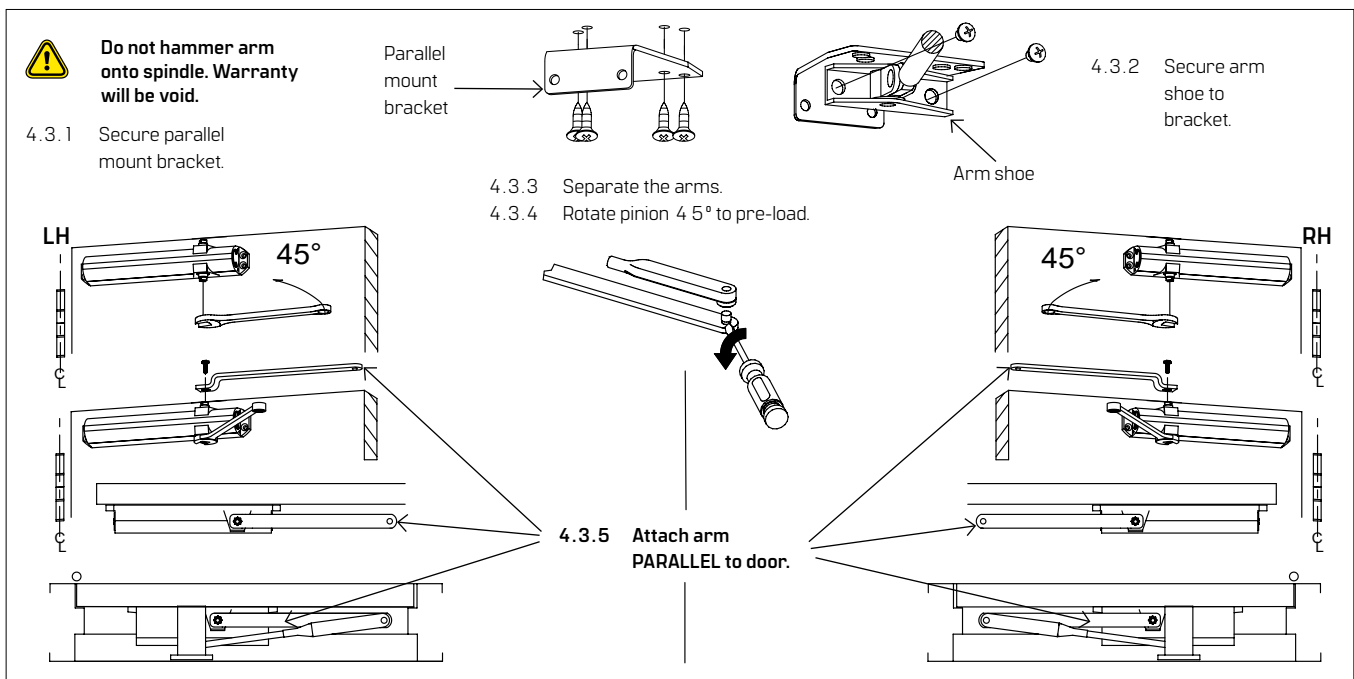

5 Adjustments

- ⚠ Confirm closer spring size prior to making any closing speed adjustments.
- ⚠ Do not back valve heads out beyond closer casting.
- ⚠ Backcheck positioning **MUST** be turned "ON" for parallel arm applications.
- ⚠ Backcheck position will advance approximately 15°.
- ⚠ Check delayed action (DEL) function if supplied.

- ⚠ Maximum opening angle is 180°.
- ⚠ Door should close in 3 to 6 seconds from 90°.
- ⚠ Do not close valves completely.
- ⚠ Ball bearing hinges and pivots should always be used.
- ⚠ HD7 0 1 6 meets 5lb interior barrier-free requirements. If necessary, adjust closer spring and test pull forces until proper forces are obtained.

5.1 Adjust closing speeds: sweep, latch, backcheck, delayed action

Fig.1 1

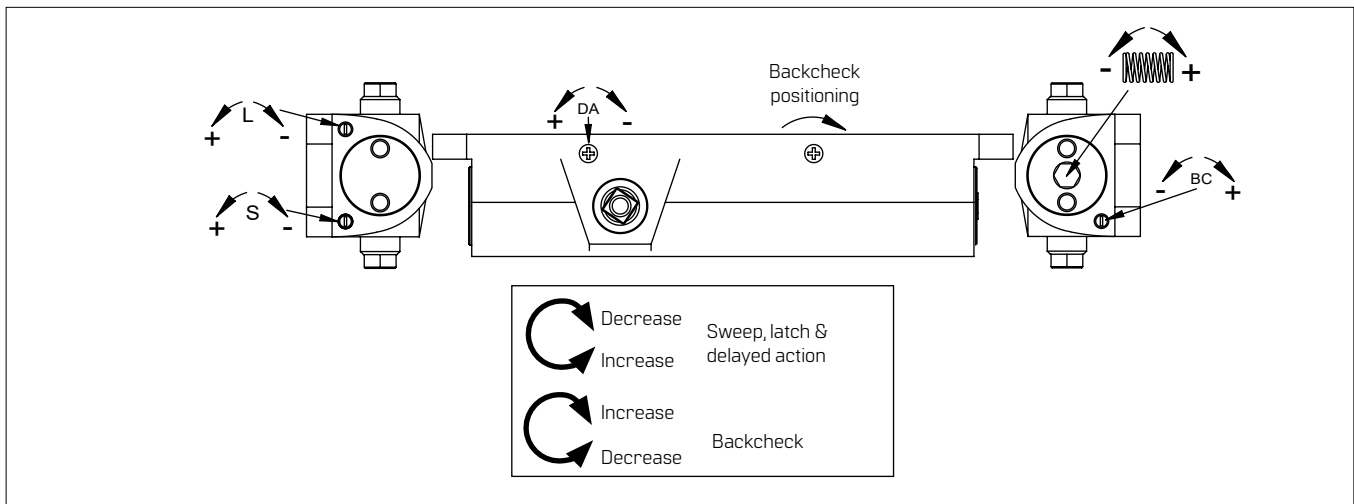

5.2 Adjust spring force

Fig.1 2

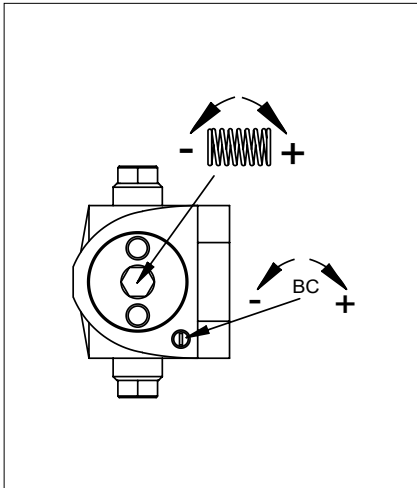

Regular and top jamb mount					
	Closer size	Max door weight (lbs)	Door width		Full turns
			Interior	Exterior	
HD7016	2	100	2'6"	----	-19
	3	125	3'	2'6"	-11
	4	150	3'6"	3'	0
	5	200	4'	3'6"	+5
	6	250	----	4'	+13
Parallel mount					
HD7016	3	100	2'6"	----	-11
	4	125	3'	2'6"	0
	5	150	3'6"	3'	+5
	6	200	4'	3'6"	+13

6 Install covers

Fig.1 3

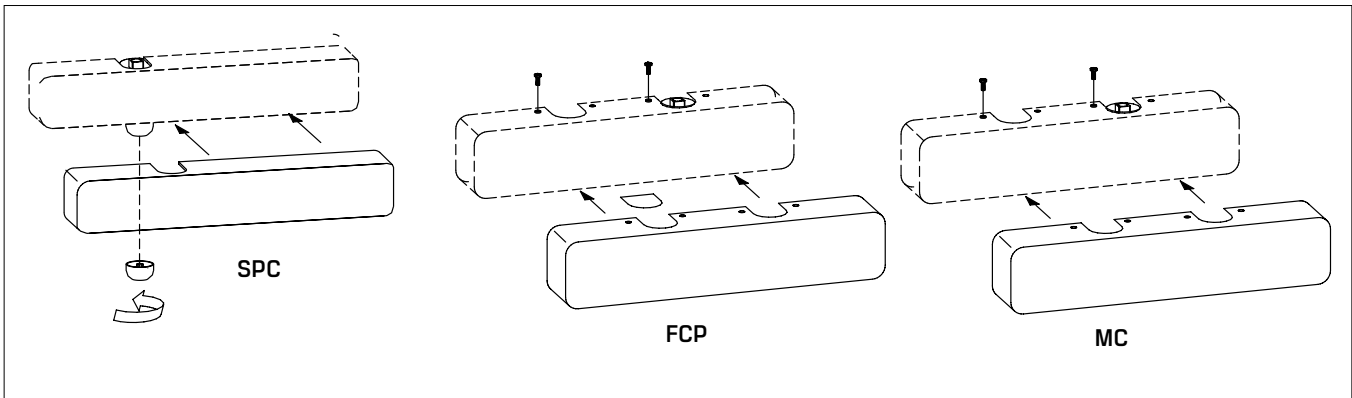

For online instructions visit:

<https://dhwsupport.dormakaba.com/hc/en-us>

For assistance or warranty information:

Call 1-800-392-5209 or visit

<https://dhwsupport.dormakaba.com/hc/en-us>