

# Door Closer Models: HD8016 and HD8056 FT Flush Track Installation [Push Side Mount] With Back Plate BP80 Drilling Instructions

For online instructions, assistance or warranty information:  
Call 1-800-392-5209 or visit <https://dhwsupport.dormakaba.com/hc/en-us>

**NOTES:**

1. DRAWING IS NOT TO SCALE.
2. DIMENSIONS ARE IN INCHES / [MM].
3. RIGHT HAND DOOR SHOWN.
4. CAUTION: SEX NUTS ARE REQUIRED FOR ATTACHMENT OF COMPONENTS TO UNREINFORCED DOORS AND TO WOOD OR PLASTIC FACED COMPOSITE TYPE FIRE DOORS, UNLESS AN ALTERNATIVE METHOD IS IDENTIFIED IN THE INDIVIDUAL DOOR MANUFACTURER'S LISTINGS.
5. MAXIMUM OPENING 125°.
6. DPK FASTENERS FOR STEEL DOOR & FRAME ONLY.

ANGLE OF MAX OPENING	DIM."A" BACK PLATE	DIM "B" TRACK
85°	6-1/8" [156]	8" [203]
90°	6-1/8" [156]	7-3/8" [187]
110°	5-1/8" [130]	6" [152]
125°	4-7/8" [124]	5-1/8" [130]

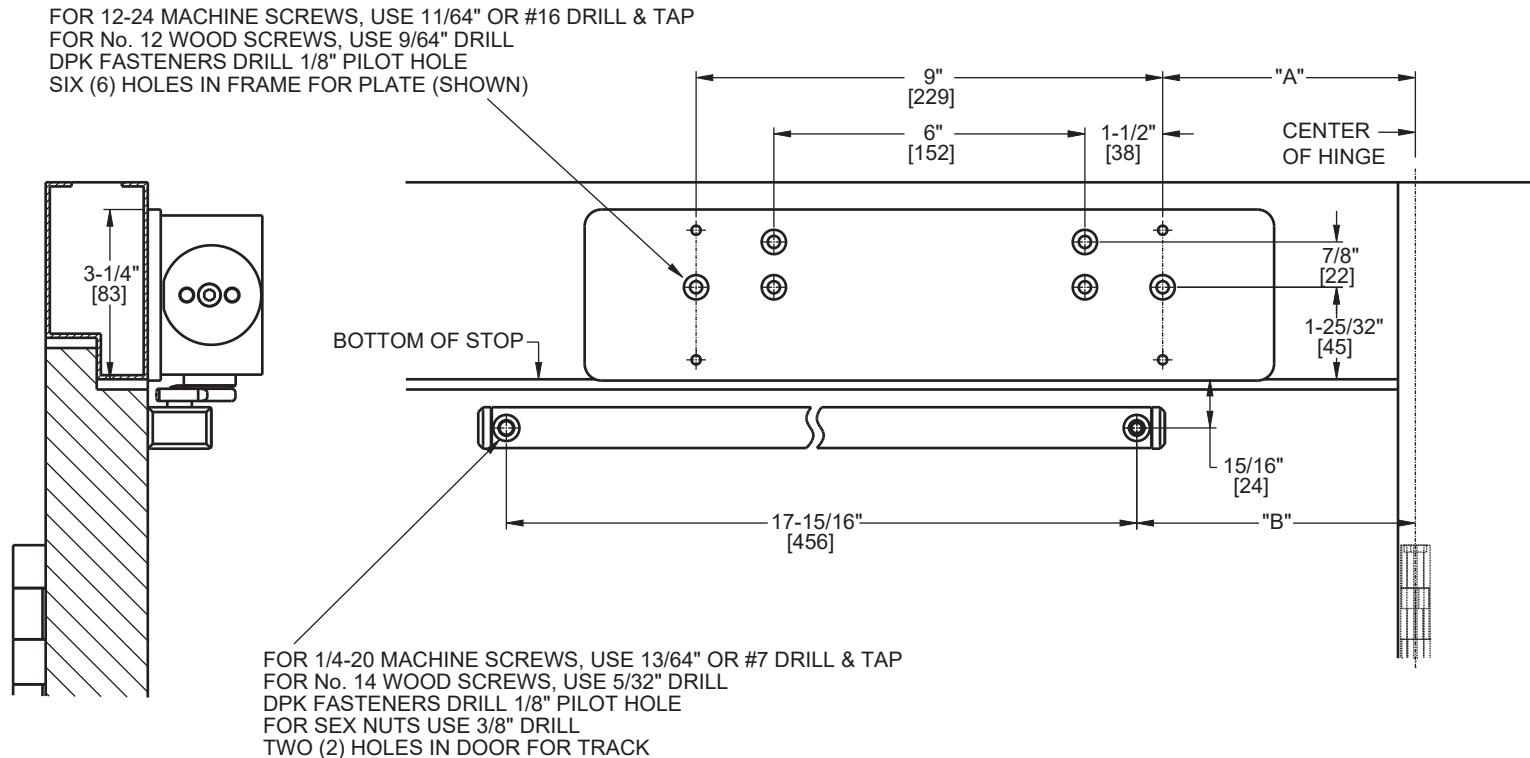

Not to scale. Measurements are for reference only.  
Not a drilling template.