

Door Closer Models: HD8016 and HD8056 TDE Double Egress Track Installation [Pull Side Mount] Drilling Instructions

For online instructions, assistance or warranty information:
Call 1-800-392-5209 or visit <https://dhwsupport.dormakaba.com/hc/en-us>

- NOTES:**
- 1) DO NOT SCALE THIS DRAWING.
 - 2) DIMENSIONS ARE IN INCHES / [MM].
 - 3) RIGHT HAND DOOR IS SHOWN.
 - 4) CAUTION: SEX NUTS ARE REQUIRED FOR ATTACHMENT OF COMPONENTS TO UNREINFORCED DOORS AND TO WOOD OR PLASTIC FACE COMPOSITE TYPE FIRE DOORS, UNLESS AN ALTERNATIVE METHOD IS IDENTIFIED IN THE INDIVIDUAL DOOR MANUFACTURER'S LISTINGS.
 - 5) TEMPLATE FOR 4-1/2" WIDE HINGES OR 3/4" OFFSET PIVOTS.
 - 6) MINIMUM DOOR WIDTH 30".
 - 7) WHEN OPENING DOOR TO 90° A MINIMUM OF 3-3/4" OF CLEARANCE IS REQUIRED BETWEEN DOOR FACE AND WALL.
 - 8) MAXIMUM OPENING 125°.
 - 9) DPK FASTENERS FOR STEEL DOOR & FRAME ONLY.

FOR 1/4-20 MACHINE SCREWS, USE 13/64" OR #7 DRILL & TAP
FOR No. 14 WOOD SCREWS, USE 5/32" DRILL
FOR DPK FASTENERS, USE 1/8" PILOT HOLE
TWO (2) HOLES IN FRAME FOR TRACK

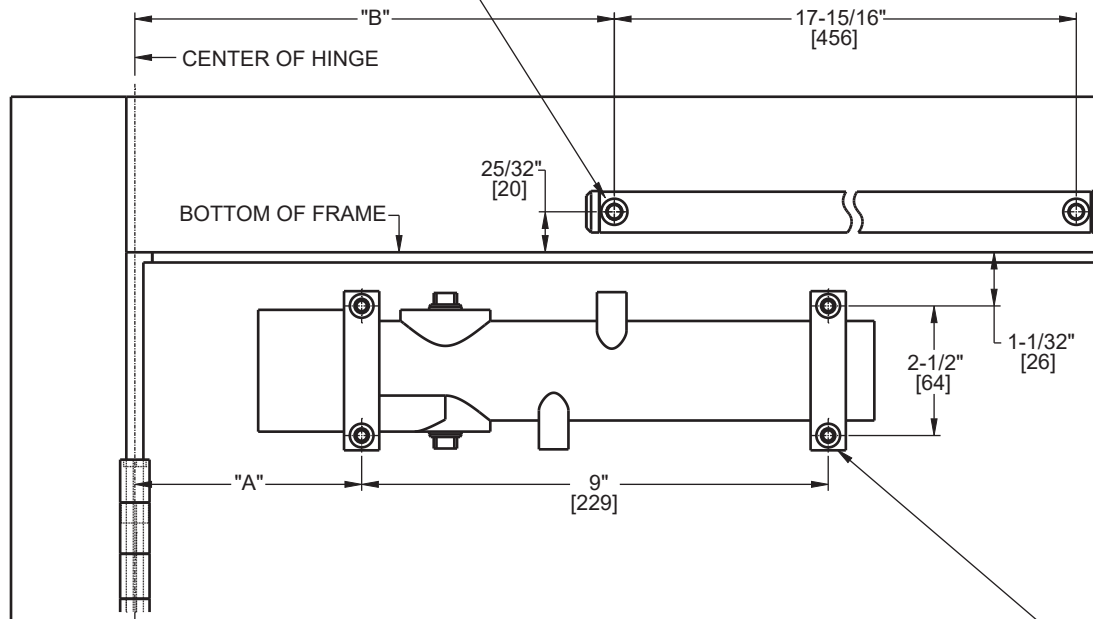

FOR 12-24 MACHINE SCREWS, USE 11/64" OR #16 DRILL & TAP
FOR No. 12 WOOD SCREWS, USE 9/64" DRILL
DPK FASTENERS DRILL 1/8" PILOT HOLE
FOR SEX NUTS, USE 3/8" DRILL
FOUR (4) HOLES IN DOOR FOR CLOSER (SHOWN)

ANGLE OF MAX OPENING	DIM."A" CLOSER	DIM."B" TRACK
125°	4-3/8" [111]	9-1/2" [241]

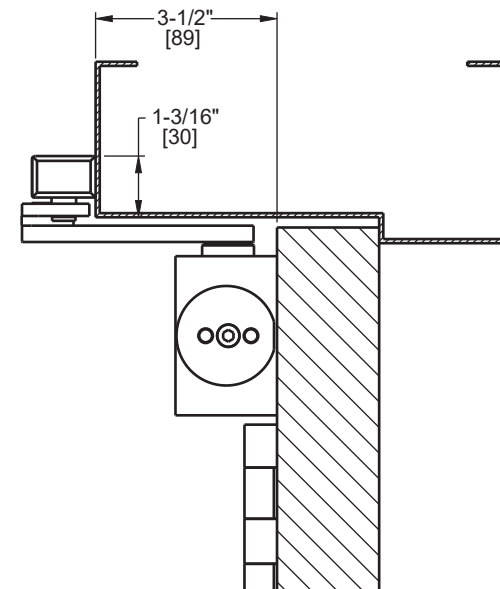

Not to scale. Measurements are for reference only.
Not a drilling template.