

# Door Closer Models: HD8016 and HD8056 DST Door Saver [Parallel Arm Mount] with Drop Plate DP80 for Use with Standard Spacer Block or Optional NFHD Bracket Drilling Instructions

For online instructions, assistance or warranty information:  
Call 1-800-392-5209 or visit <https://dhwsupport.dormakaba.com/hc/en-us>

ANGLE OF HOLD OPEN	ANGLE OF CUSHION	DIM."A" DROP PLATE	DIM "B" SOFFIT
85°	85° - 86°	11-5/8" [295]	11" [279]
90°	90° - 91°	10-7/8" [276]	10-1/4" [260]
100°	100° - 101°	9-9/16" [243]	8-15/16" [227]
110°	110° - 111°	8-7/16" [214]	7-13/16" [198]

- NOTES:
- 1) DRAWING IS NOT TO SCALE.
  - 2) DIMENSIONS ARE IN INCHES / [MM].
  - 3) RIGHT HAND DOOR IS SHOWN.
  - 4) CAUTION: SEX NUTS ARE REQUIRED FOR ATTACHMENT OF COMPONENTS TO UNREINFORCED DOORS AND TO WOOD OR PLASTIC FACE COMPOSITE TYPE FIRE DOORS, UNLESS AN ALTERNATIVE METHOD IS IDENTIFIED IN THE INDIVIDUAL DOOR MANUFACTURER'S LISTINGS.
  - 5) FOR FRAME WIDTHS 4-1/2" AND LESS, USE OPTIONAL NFHD BRACKET W/O STANDARD SPACER BLOCK.
  - 6) MINIMUM DOOR WIDTH IS 26".
  - 7) DPK FASTENERS FOR STEEL DOOR & FRAME ONLY.

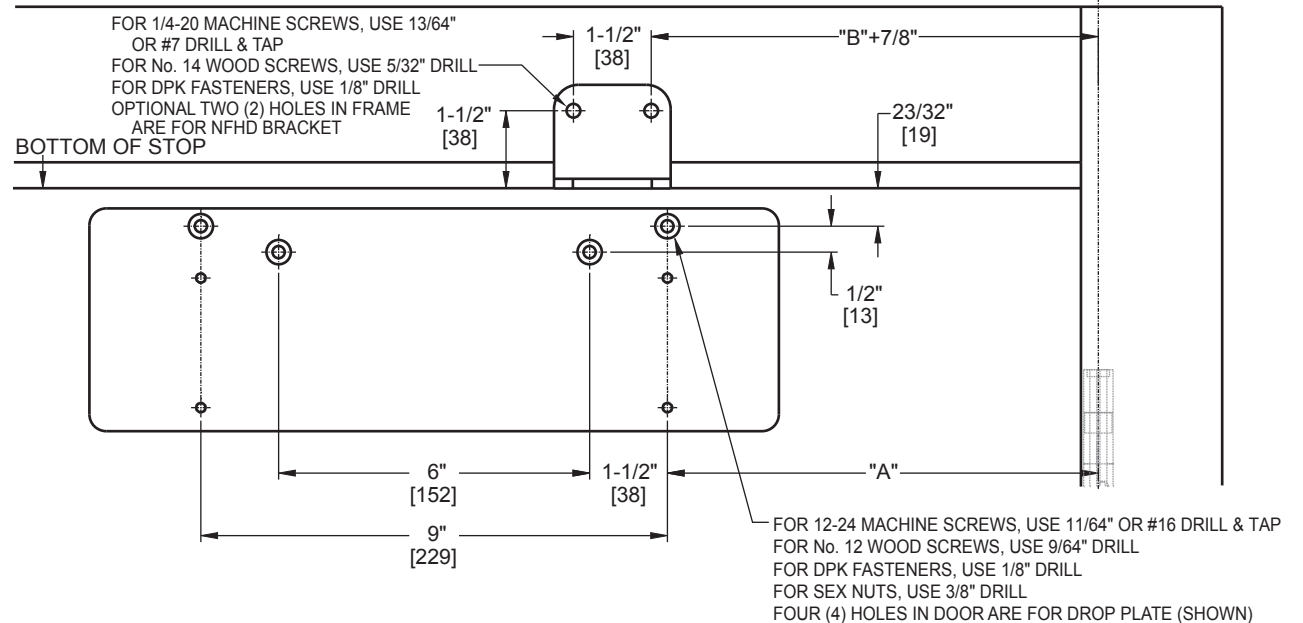
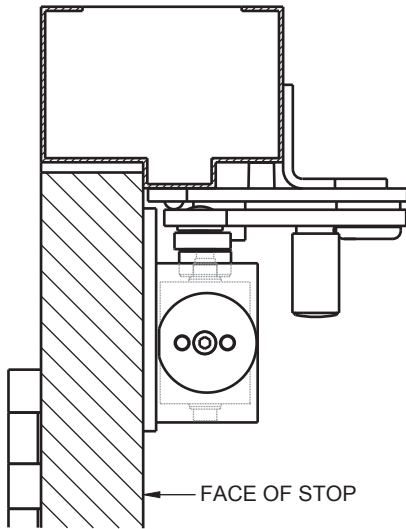
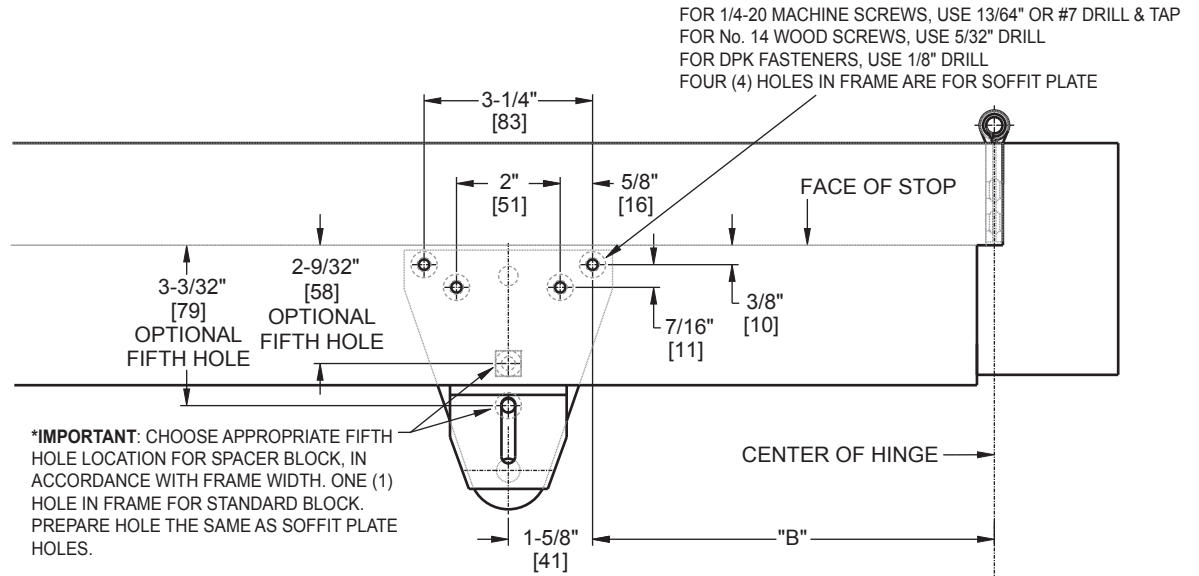

Not to scale. Measurements are for reference only.  
Not a drilling template.