

Door Closer Models: HD8016 and HD8056 AF80 x PD Parallel Arm Installation [Push Side Mount] With Drop Plate DP80 Drilling Instructions

For online instructions, assistance or warranty information:
Call 1-800-392-5209 or visit <https://dhwsupport.dormakaba.com/hc/en-us>

NOTES:

1. DO NOT SCALE DRAWING.
2. DIMENSIONS ARE IN INCHES/[MM].
3. RIGHT HAND DOOR SHOWN.
4. CAUTION: SEX NUTS ARE REQUIRED FOR ATTACHMENT OF COMPONENTS TO UNREINFORCED DOORS AND TO WOOD OR PLASTIC FACED COMPOSITE TYPE FIRE DOORS, UNLESS AN ALTERNATIVE METHOD IS IDENTIFIED IN THE INDIVIDUAL DOOR MANUFACTURER'S LISTINGS.
5. MAXIMUM OPENING 180°.
6. DPK FASTENERS FOR STEEL DOOR & FRAME ONLY.

ANGLE OF MAX OPENING	DIM."A" PLATE	DIM."B" ARM PLATE
100°	12" [305]	10" [254]
180°	8-1/2" [216]	6-1/2" [165]

FOR 1/4-20 MACHINE SCREWS, USE 13/64" OR #7 DRILL & TAP
FOR No. 14 WOOD SCREWS USE 5/32" DRILL
DPK FASTENERS DRILL 1/8" PILOT HOLE
FOUR (4) HOLES IN SOFFIT FOR BRACKET

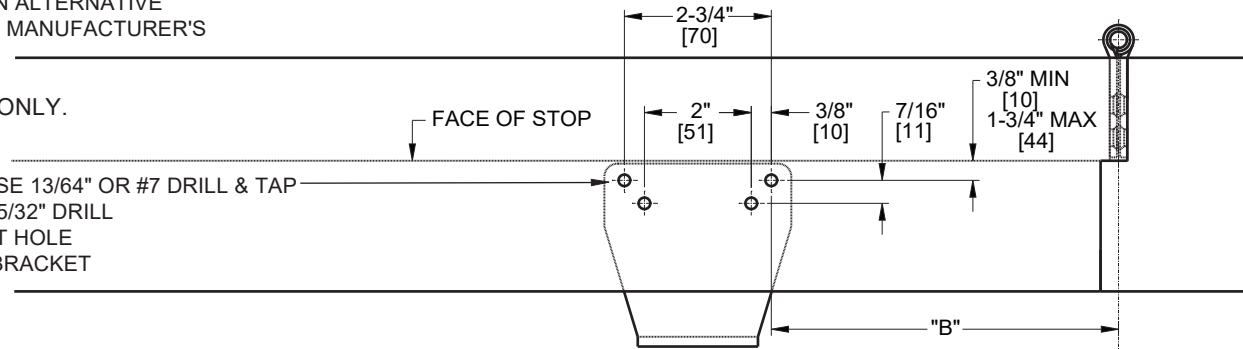

FOR 12-24 MACHINE SCREWS, USE 11/64" OR #16 DRILL & TAP
FOR No. 12 WOOD SCREWS, USE 9/64" DRILL
DPK FASTENERS DRILL 1/8" PILOT HOLE
FOR SEX NUTS USE 3/8" DRILL
FOUR (4) HOLES IN DOOR FOR PLATE

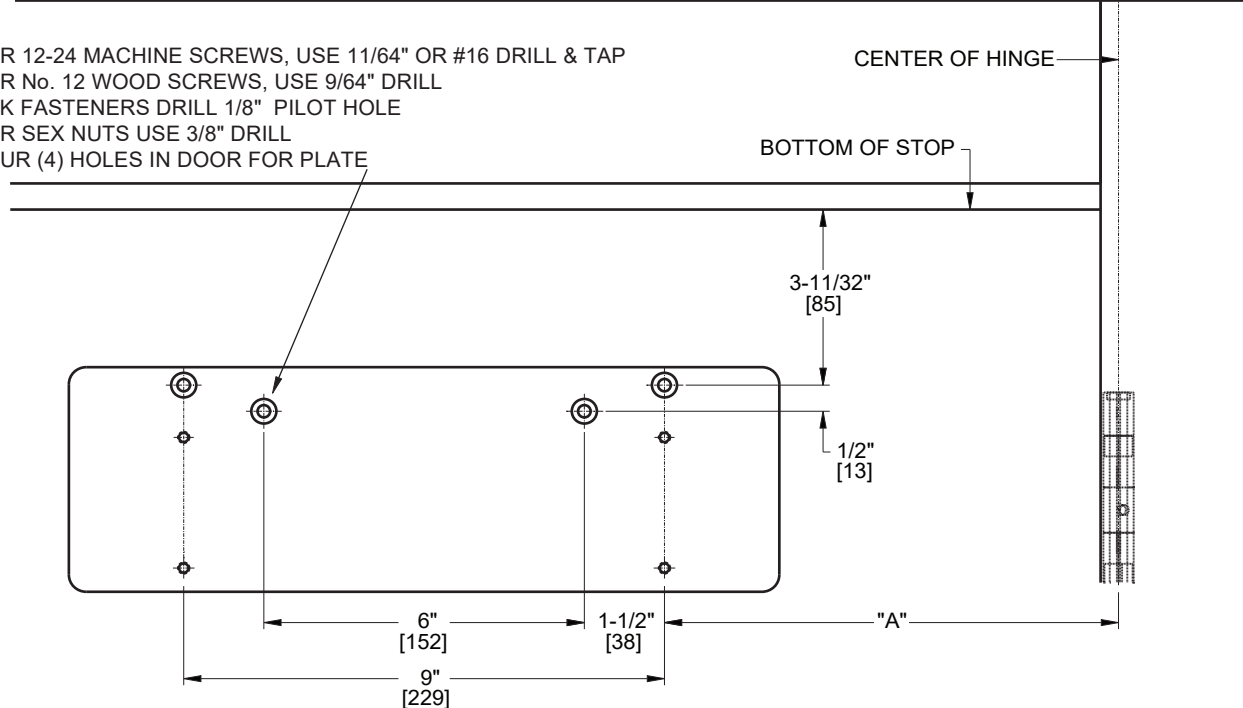
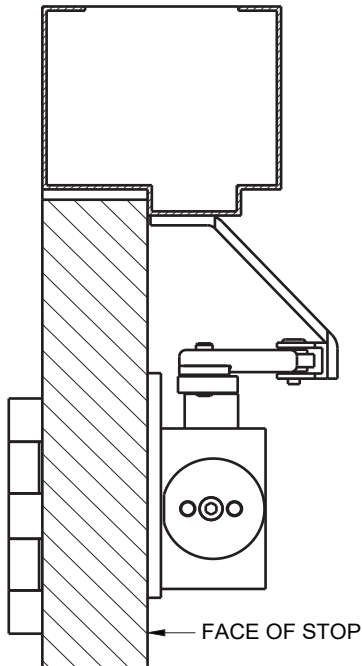

Not to scale. Measurements are for reference only.
Not a drilling template.