

# Door Closer Models: HD8016 and HD8056 AF80P, PHP Parallel Arm Installation [Push Side Mount] With Drop Plate DP80 Drilling Instructions

For online instructions, assistance or warranty information:  
Call 1-800-392-5209 or visit <https://dhwsupport.dormakaba.com/hc/en-us>

**NOTES:**

- 1) DO NOT SCALE THIS DRAWING.
- 2) DIMENSIONS ARE IN INCHES / [MM].
- 3) RIGHT HAND DOOR IS SHOWN.
- 4) CAUTION: SEX NUTS ARE REQUIRED FOR ATTACHMENT OF COMPONENTS TO UNREINFORCED DOORS AND TO WOOD OR PLASTIC FACE COMPOSITE TYPE FIRE DOORS, UNLESS AN ALTERNATIVE METHOD IS IDENTIFIED IN THE INDIVIDUAL DOOR MANUFACTURER'S LISTINGS.
- 5) MAXIMUM OPENING 180°.
- 6) DPK FASTENERS FOR STEEL DOOR & FRAME ONLY.
- 7) SEE CATALOG FOR HOLD OPEN RANGE.

ANGLE OF MAX OPENING	DIM."A" CLOSER	DIM."B" ARM PLATE
100°	12" [305]	10" [254]
180°	8-1/2" [216]	6-1/2" [165]

FOR 1/4-20 MACHINE SCREWS, USE 13/64" OR #7 DRILL & TAP  
FOR No. 14 WOOD SCREWS, USE 5/32" DRILL  
DPK FASTENERS, DRILL 1/8" PILOT HOLE  
FIVE (5) HOLES IN SOFFIT FOR BRACKET

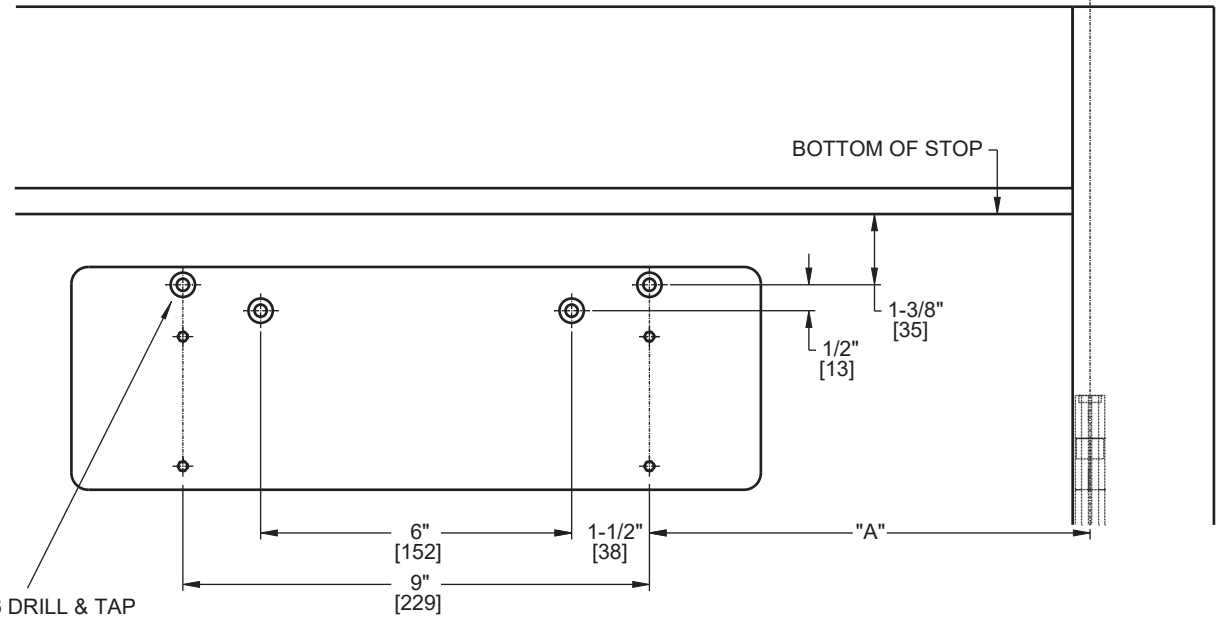
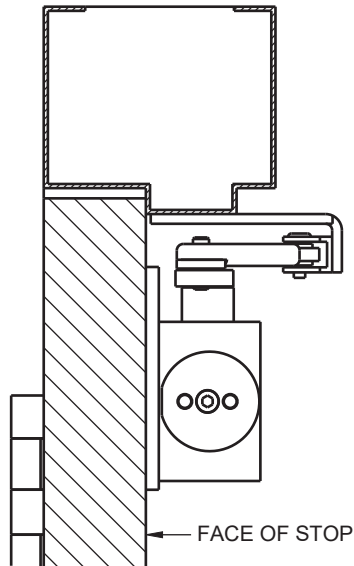
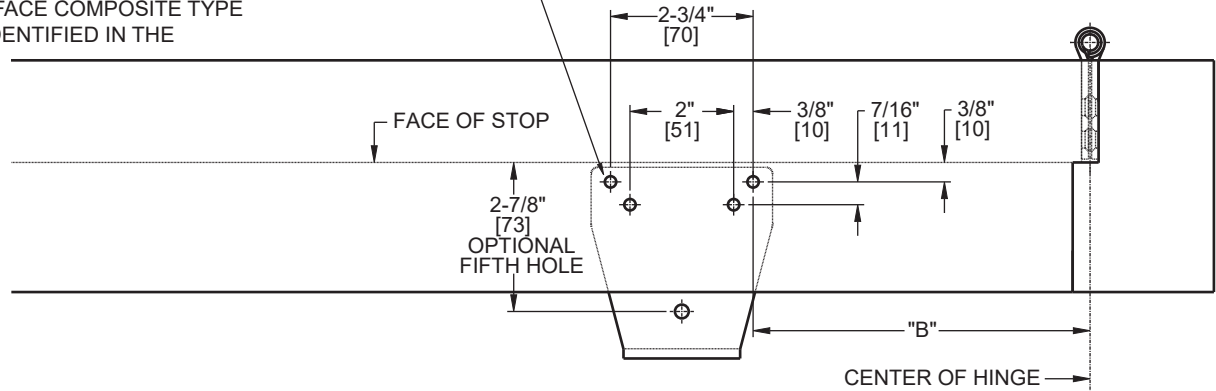

FOR 12-24 MACHINE SCREWS, USE 11/64" OR #16 DRILL & TAP  
FOR No. 12 WOOD SCREWS, USE 9/64" DRILL  
FOR DPK FASTENERS, DRILL 1/8" PILOT HOLE  
FOR SEX NUTS, USE 3/8" DRILL  
FOUR (4) HOLES IN DOOR ARE FOR PLATE (SHOWN)

Not to scale. Measurements are for reference only.  
Not a drilling template.