

Door Closer Models: HD8016 and HD8056 FHJ Top Jamb Installation [Push Side Mount] With Back Plate BP80 Drilling Instructions

For online instructions, assistance or warranty information:
Call 1-800-392-5209 or visit <https://dhwsupport.dormakaba.com/hc/en-us>

NOTES:

1. DO NOT SCALE DRAWING.
2. RIGHT HAND DOOR SHOWN.
3. DIMENSIONS ARE IN INCHES/[MM].
4. CAUTION: SEX NUTS ARE REQUIRED FOR ATTACHMENT OF COMPONENTS TO UNREINFORCED DOORS AND TO WOOD OR PLASTIC FACED COMPOSITE TYPE FIRE DOORS, UNLESS AN ALTERNATIVE METHOD IS IDENTIFIED IN THE INDIVIDUAL DOOR MANUFACTURER'S LISTINGS.
5. SEE CATALOG FOR REVEAL AND HOLD OPEN RANGE INFORMATION.

ANGLE OF MAX OPENING	DIM."A" PLATE	DIM."B" SOFFIT
100°	9" [229]	12-3/8" [314]
180°	5-3/4" [146]	9-1/8" [232]

FOR 12-24 MACHINE SCREWS, USE 11/64" OR #16 DRILL & TAP
FOR No. 12 WOOD SCREWS, USE 9/64" DRILL
DPK FASTENERS DRILL 1/8" PILOT HOLE
SIX (6) HOLES IN FRAME FOR PLATE

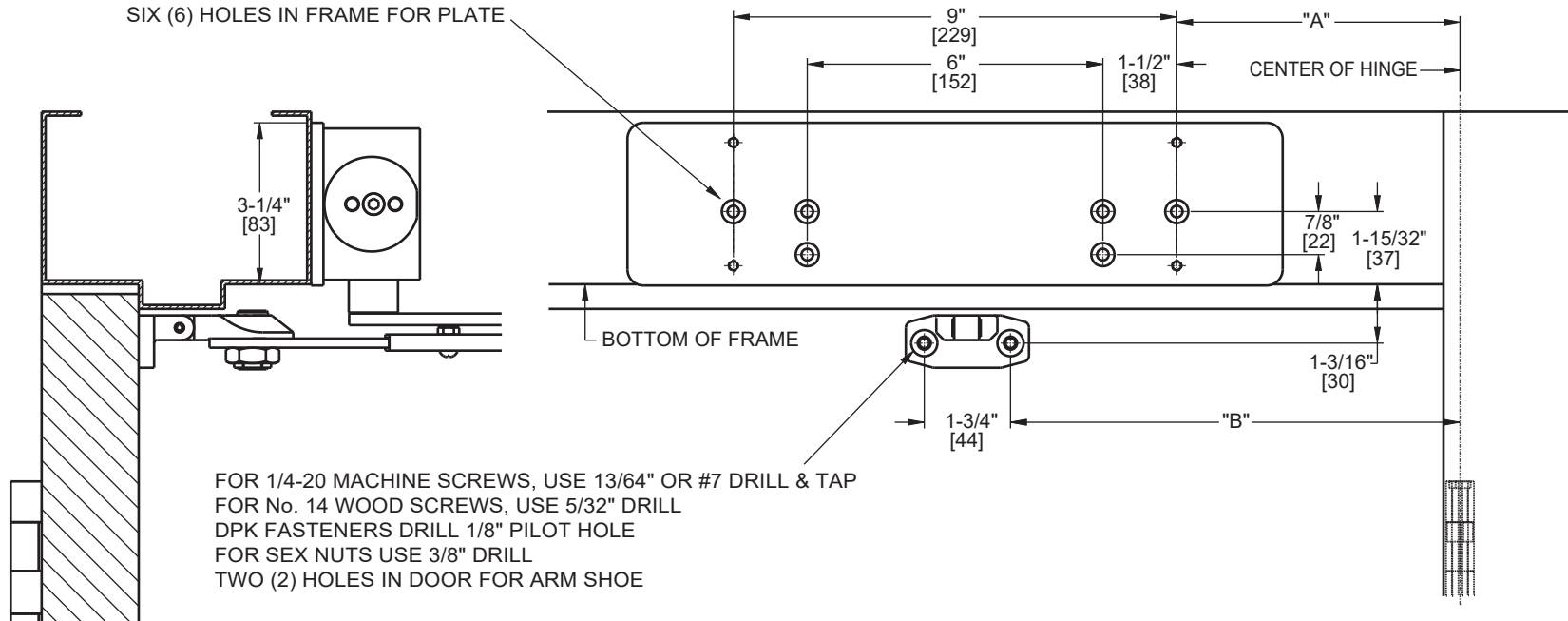

FOR 1/4-20 MACHINE SCREWS, USE 13/64" OR #7 DRILL & TAP
FOR No. 14 WOOD SCREWS, USE 5/32" DRILL
DPK FASTENERS DRILL 1/8" PILOT HOLE
FOR SEX NUTS USE 3/8" DRILL
TWO (2) HOLES IN DOOR FOR ARM SHOE

Not to scale. Measurements are for reference only.
Not a drilling template.