

# Door Closer Models: HD8016 and HD8056 FHP Parallel Arm Installation [Push Side Mount] Drilling Instructions

For online instructions, assistance or warranty information:  
Call 1-800-392-5209 or visit <https://dhwsupport.dormakaba.com/hc/en-us>

**NOTES:**

1. DO NOT SCALE DRAWING.
2. RIGHT HAND DOOR SHOWN.
3. DIMENSIONS ARE IN INCHES/[MM].
4. CAUTION: SEX NUTS ARE REQUIRED FOR ATTACHMENT OF COMPONENTS TO UNREINFORCED DOORS AND TO WOOD OR PLASTIC FACED COMPOSITE TYPE FIRE DOORS, UNLESS AN ALTERNATIVE METHOD IS IDENTIFIED IN THE INDIVIDUAL DOOR MANUFACTURER'S LISTINGS.
5. MAXIMUM OPENING 180°.
6. SEE CATALOG FOR HOLD OPEN RANGE INFORMATION.
7. DPK FASTENERS FOR STEEL DOOR & FRAME ONLY.

ANGLE OF MAX OPENING	DIM. "A" CLOSER	DIM. "B" SOFFIT
100°	10-5/8" [270]	10-1/4" [260]
180°	7-1/4" [184]	6-7/8" [175]

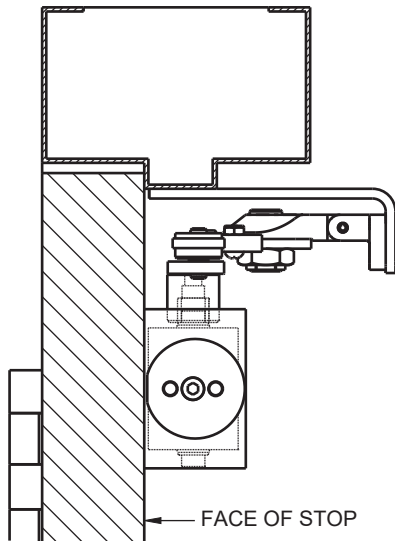

FOR 1/4-20 MACHINE SCREWS, USE 13/64" OR #7 DRILL & TAP  
FOR No. 14 WOOD SCREWS, USE 5/32" DRILL  
DPK FASTENERS DRILL 1/8" PILOT HOLE  
FIVE (5) HOLES IN SOFFIT FOR BRACKET

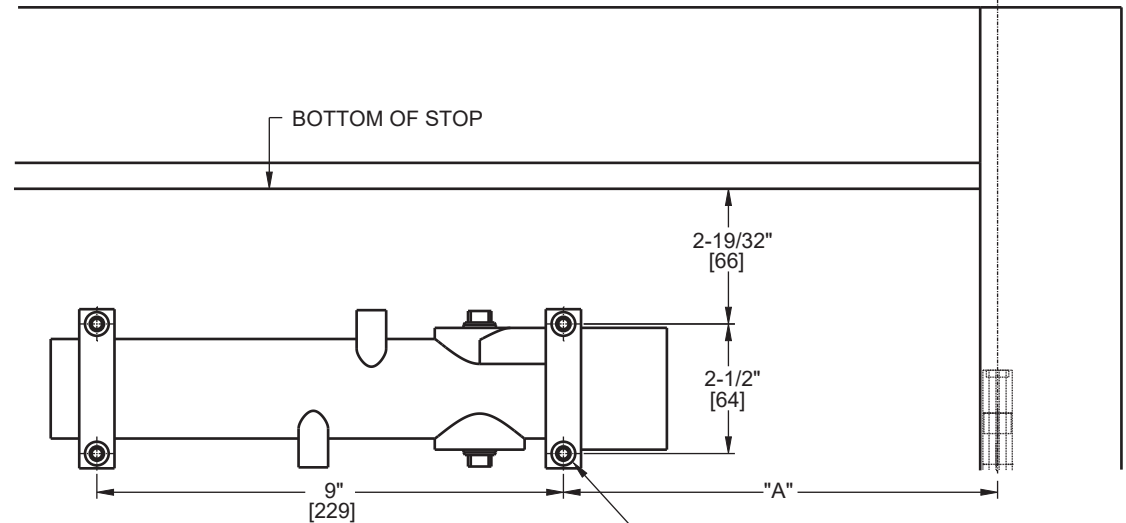
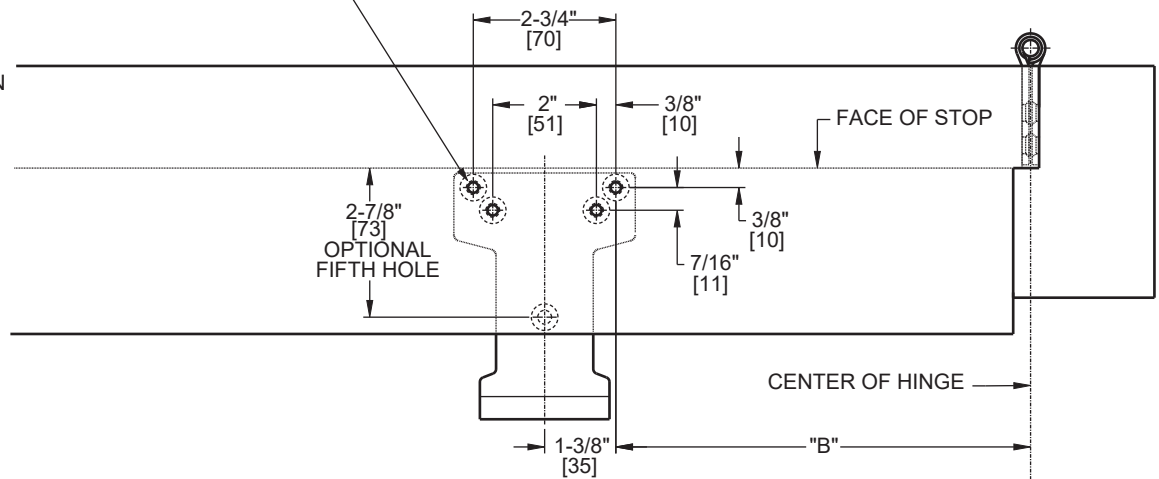

FOR #12-24 MACHINE SCREWS, USE 11/64" OR #16 DRILL & TAP  
FOR No. 12 WOOD SCREWS USE 9/64" DRILL  
DPK FASTENERS DRILL 1/8" PILOT HOLE  
FOR SEX NUTS USE 3/8" DRILL  
FOUR (4) HOLES IN DOOR FOR CLOSER

Not to scale. Measurements are for reference only.  
Not a drilling template.