

# Door Closer Models: HD8016 and HD8056 AF80 x MJ Regular Installation [Pull Side Mount] Drilling Instructions

For online instructions, assistance or warranty information:  
Call 1-800-392-5209 or visit <https://dhwsupport.dormakaba.com/hc/en-us>

FOR 1/4-20 MACHINE SCREWS, USE 13/64" OR #7 DRILL & TAP  
FOR No. 14 WOOD SCREWS USE 5/32" DRILL  
DPK FASTENERS DRILL 1/8" PILOT HOLE  
THREE (3) HOLES IN RABBET FOR BRACKET

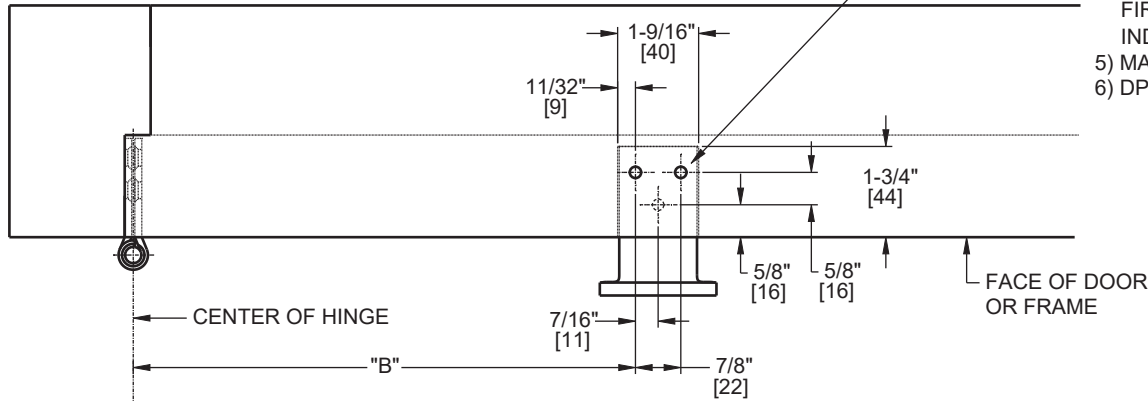

**NOTES:**

- 1) DO NOT SCALE THIS DRAWING.
- 2) DIMENSIONS ARE IN INCHES / [MM].
- 3) RIGHT HAND DOOR IS SHOWN.
- 4) CAUTION: SEX NUTS ARE REQUIRED FOR ATTACHMENT OF COMPONENTS TO UNREINFORCED DOORS AND TO WOOD OR PLASTIC FACE COMPOSITE TYPE FIRE DOORS, UNLESS AN ALTERNATIVE METHOD IS IDENTIFIED IN THE INDIVIDUAL DOOR MANUFACTURER'S LISTINGS.
- 5) MAXIMUM OPENING 180°.
- 6) DPK FASTENERS FOR STEEL DOOR & FRAME ONLY.

ANGLE OF MAX OPENING	DIM."A" CLOSER	DIM."B" ARM PLATE
100°	8-3/4" [222]	13-11/16" [348]
180°	4-3/4" [121]	9-11/16" [246]

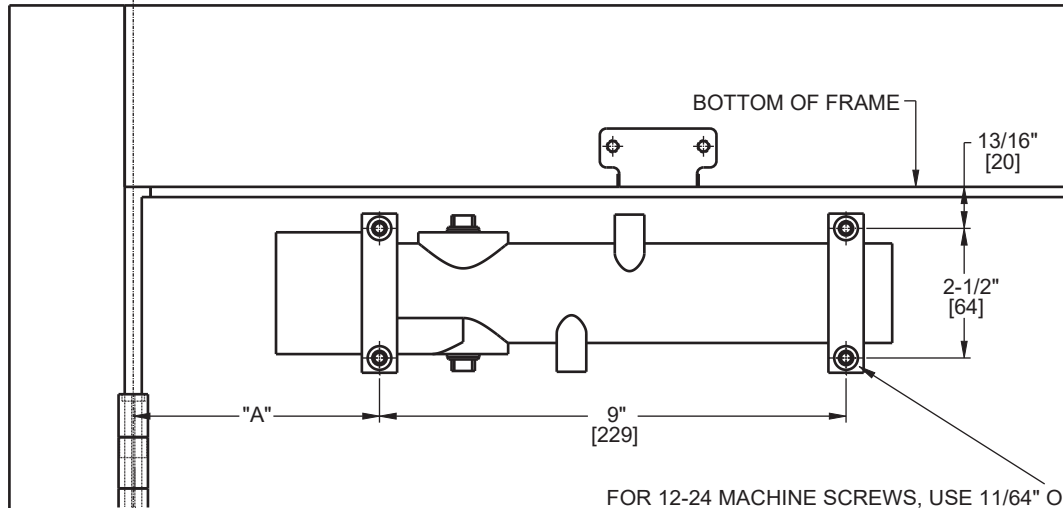

FOR 12-24 MACHINE SCREWS, USE 11/64" OR #16 DRILL & TAP  
FOR No. 12 WOOD SCREWS, USE 9/64" DRILL  
DPK FASTENERS DRILL 1/8" PILOT HOLE  
FOR SEX NUTS USE 3/8" DRILL  
FOUR (4) HOLES IN DOOR FOR CLOSER

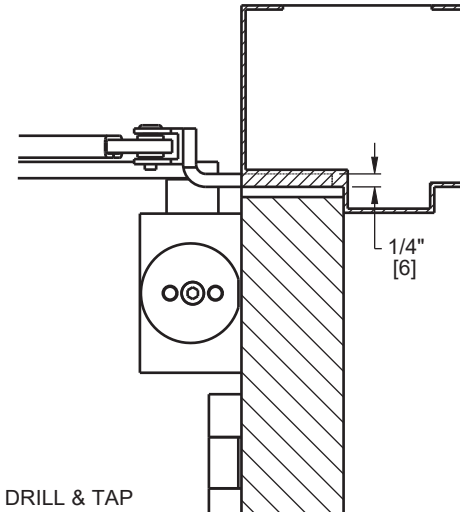

Not to scale. Measurements are for reference only.  
Not a drilling template.