

Door Closer Models: HD8016 and HD8056 IS Regular Installation [Pull Side Mount] With Back Plate BP80 Integra Cushion Arm Drilling Instructions

For online instructions, assistance or warranty information:
Call 1-800-392-5209 or visit <https://dhwsupport.dormakaba.com/hc/en-us>

NOTES:

- 1) DO NOT SCALE THIS DRAWING.
- 2) DIMENSIONS ARE IN INCHES / [MM].
- 3) RIGHT HAND DOOR IS SHOWN.
- 4) CAUTION: SEX NUTS ARE REQUIRED FOR ATTACHMENT OF COMPONENTS TO UNREINFORCED DOORS AND TO WOOD OR PLASTIC FACE COMPOSITE TYPE FIRE DOORS, UNLESS AN ALTERNATIVE METHOD IS IDENTIFIED IN THE INDIVIDUAL DOOR MANUFACTURER'S LISTINGS.
- 5) DPK FASTENERS FOR STEEL DOOR & FRAME ONLY.

ANGLE OF CUSHION	DIM."A" CLOSER	DIM."B" ARM SHOE
85 °	10-3/8" [264]	13-1/8" [333]
90 °	9-3/4" [248]	12-1/2" [318]
95 °	9-1/4" [235]	12" [305]
100 °	8-13/16" [224]	11-9/16" [294]
105 °	8-7/16" [214]	11-3/16" [284]
110 °	8-1/16" [205]	10-13/16" [275]

FOR 1/4-20 MACHINE SCREWS, USE 13/64" OR #7 DRILL & TAP
FOR No. 14 WOOD SCREWS, USE 5/32" DRILL
FOR DPK FASTENERS, USE 1/8" DRILL
TWO (2) HOLES IN FRAME ARE FOR ARM SHOE (SHOWN)

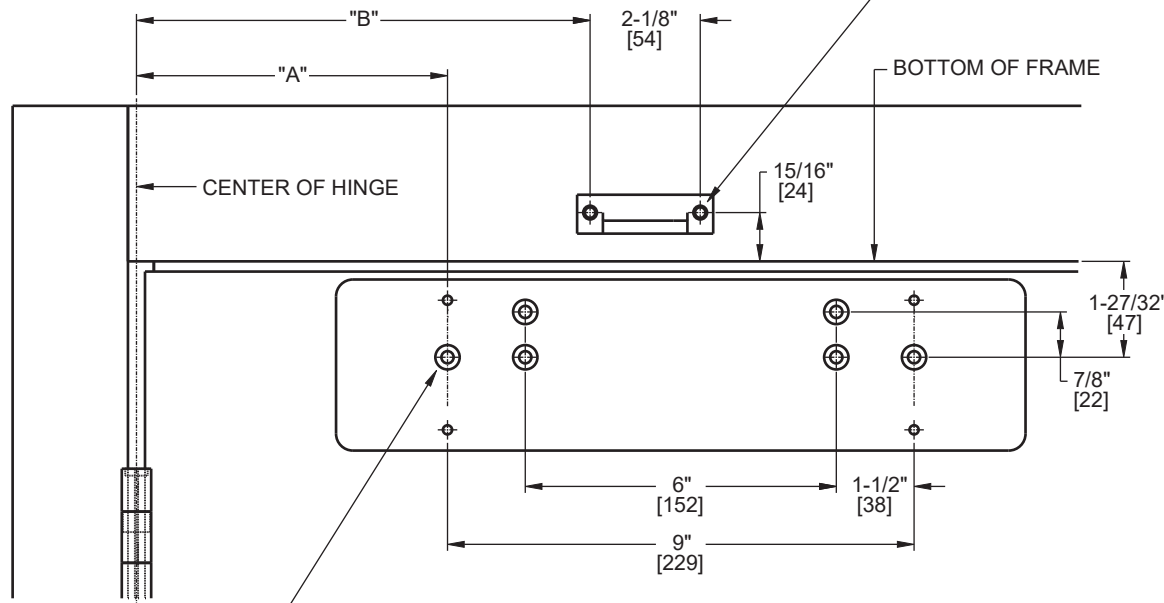

FOR 12-24 MACHINE SCREWS, USE 11/64" OR #16 DRILL & TAP
FOR No. 12 WOOD SCREWS, USE 9/64" DRILL
FOR DPK FASTENERS, USE 1/8" DRILL
FOR SEX NUTS, USE 3/8" DRILL
SIX (6) HOLES IN DOOR ARE FOR BACK PLATE (SHOWN)

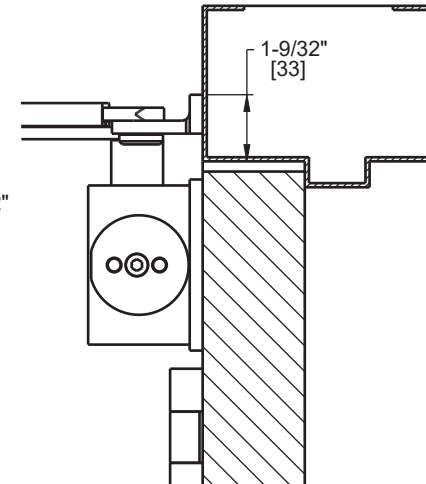

Not to scale. Measurements are for reference only.
Not a drilling template.