

# Door Closer Models: HD7016 DS, DST x FTHD Door Saver Arm Flush Transom Installation [Push Side Mount] with Plates DP70, DP70FC Drilling Instructions

For online instructions, assistance or warranty information:  
Call 1-800-392-5209 or visit <https://dhwsupport.dormakaba.com/hc/en-us>

**NOTES:**

1. DO NOT SCALE DRAWING.
2. DIMENSIONS ARE IN INCHES/(MM).
3. LEFT HAND DOOR SHOWN.
4. CAUTION: SEX NUTS ARE REQUIRED FOR ATTACHMENT OF COMPONENTS TO UNREINFORCED DOORS AND TO WOOD OR PLASTIC FACED COMPOSITE TYPE FIRE DOORS, UNLESS AN ALTERNATIVE METHOD IS IDENTIFIED IN THE INDIVIDUAL DOOR MANUFACTURER'S LISTINGS.
5. MINIMUM DOOR WIDTH 26"
6. TEMPLATING BASED ON 4-1/2" x 2-1/2" BUTT HINGES.
7. HOLD OPEN AND DEAD STOP ARE SAME LOCATION.
8. DPK FASTENERS FOR STEEL DOOR & FRAME ONLY.

ANGLE OF OPENING DEADSTOP	DIM. "C" PLATE	DIM. "B" FTHD BRACKET
85°	9-5/8 [244]	11 [279]
90°	8-7/8 [225]	10-1/4 [260]
100°	7-5/8 [194]	9 [229]
110°	6-1/2 [165]	7-7/8 [200]

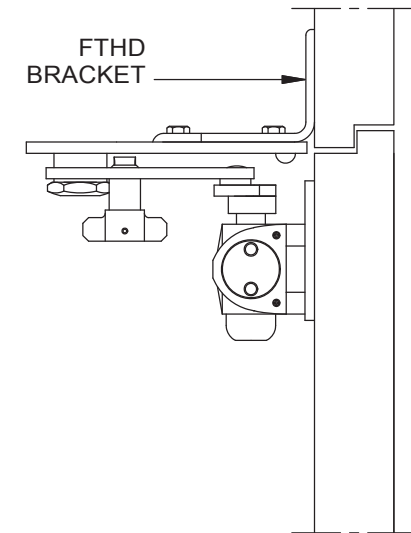
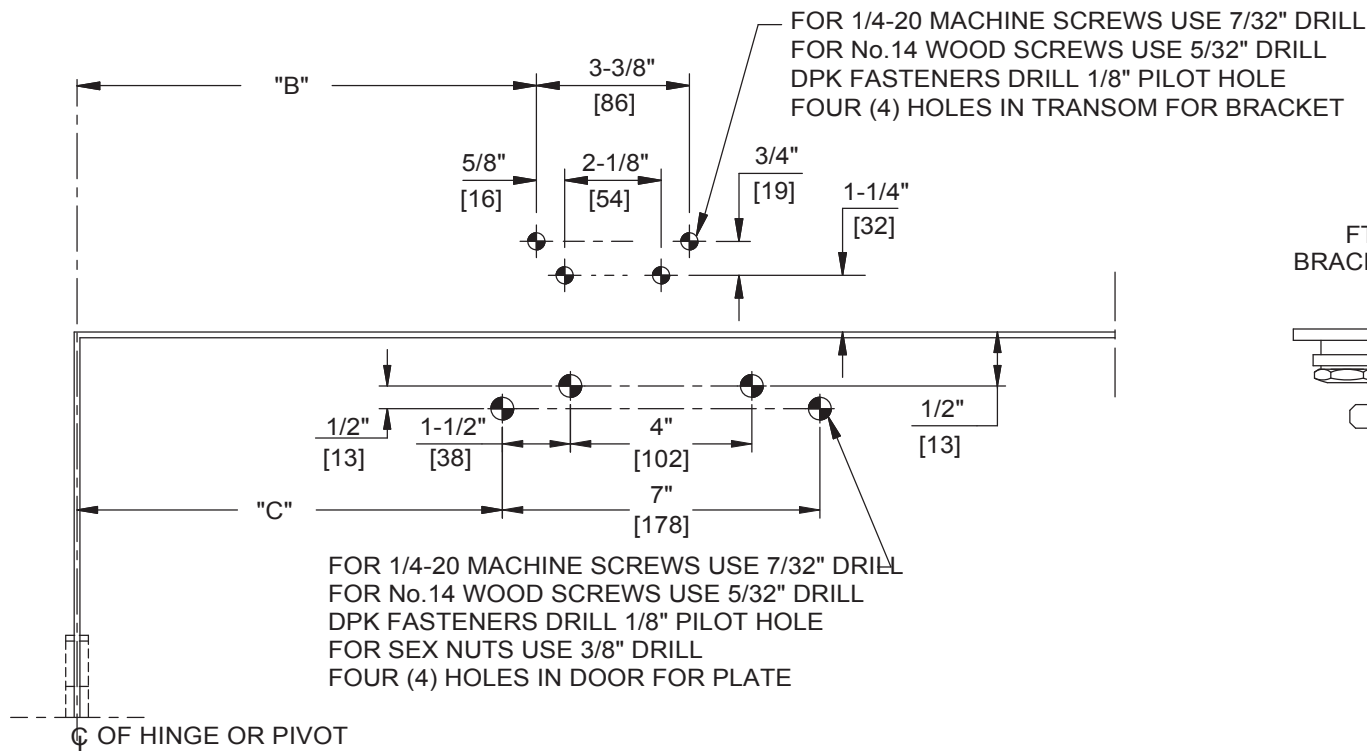

Not to scale. Measurements are for reference only.  
Not a drilling template.