

Door Closer Models: HD7016 AF x MJ Regular Installation [Pull Side Mount] with Plates BP70, BP70FC Drilling Instructions

For online instructions, assistance or warranty information:
Call 1-800-392-5209 or visit <https://dhwsupport.dormakaba.com/hc/en-us>

FOR 1/4-20 MACHINE SCREWS USE 7/32" DRILL & TAP
FOR No. 14 WOOD SCREWS USE 5/32" DRILL
DPK FASTENERS DRILL 1/8" PILOT HOLE
THREE (3) HOLES IN RABBET FOR BRACKET

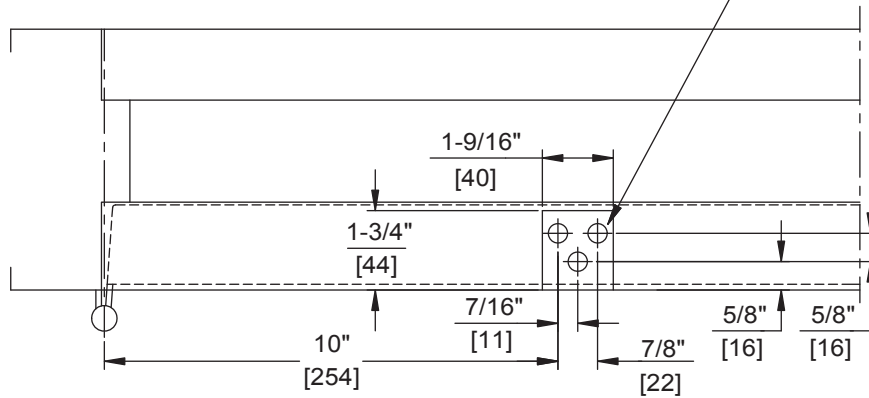

NOTES:

1. DO NOT SCALE DRAWING.
2. DIMENSIONS ARE IN INCHES/(MM).
3. RIGHT HAND DOOR SHOWN.
4. CAUTION: SEX NUTS ARE REQUIRED FOR ATTACHMENT OF COMPONENTS TO UNREINFORCED DOORS AND TO WOOD OR PLASTIC FACED COMPOSITE TYPE FIRE DOORS, UNLESS AN ALTERNATIVE METHOD IS IDENTIFIED IN THE INDIVIDUAL DOOR MANUFACTURER'S LISTINGS.
5. MAX. OPENING IS 180°.
6. DPK FASTENERS FOR STEEL DOOR & FRAME ONLY.

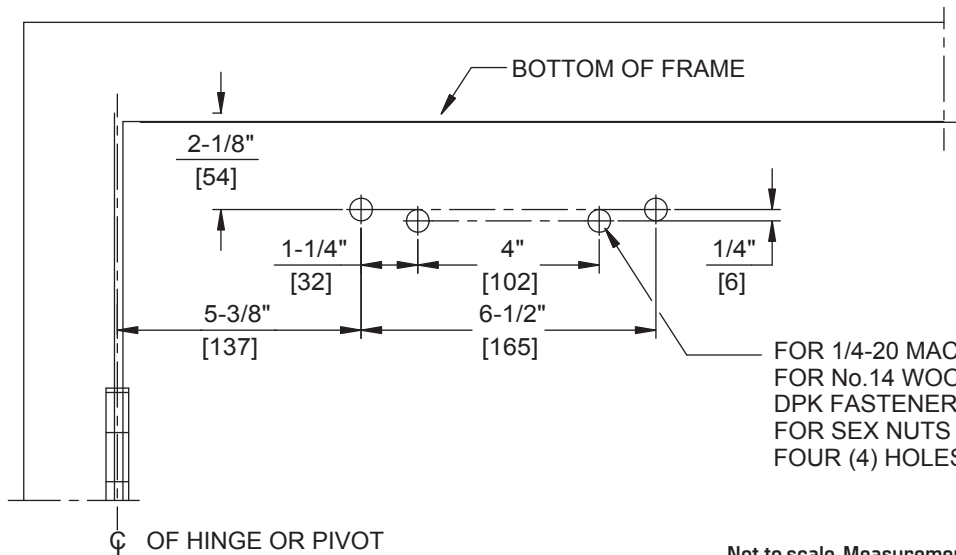

FOR 1/4-20 MACHINE SCREWS USE 7/32" DRILL & TAP
FOR No. 14 WOOD SCREWS USE 5/32" DRILL
DPK FASTENERS DRILL 1/8" PILOT HOLE
FOR SEX NUTS USE 3/8" DRILL
FOUR (4) HOLES IN DOOR FOR PLATE

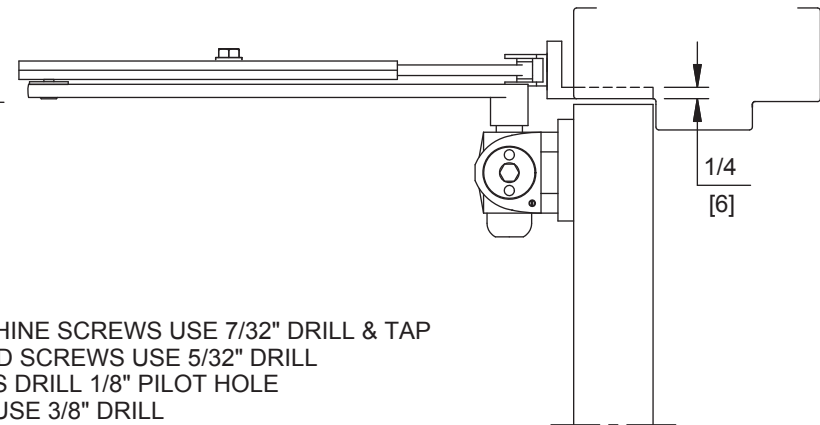

Not to scale. Measurements are for reference only.
Not a drilling template.