

**Door Closer Models: HD7016 PHP Parallel Arm Installation
(Push Side Mount) (Plunger Hold Open Arm)
Drilling Instructions**

For online instructions, assistance or warranty information:
Call 1-800-392-5209 or visit <https://dhwsupport.dormakaba.com/hc/en-us>

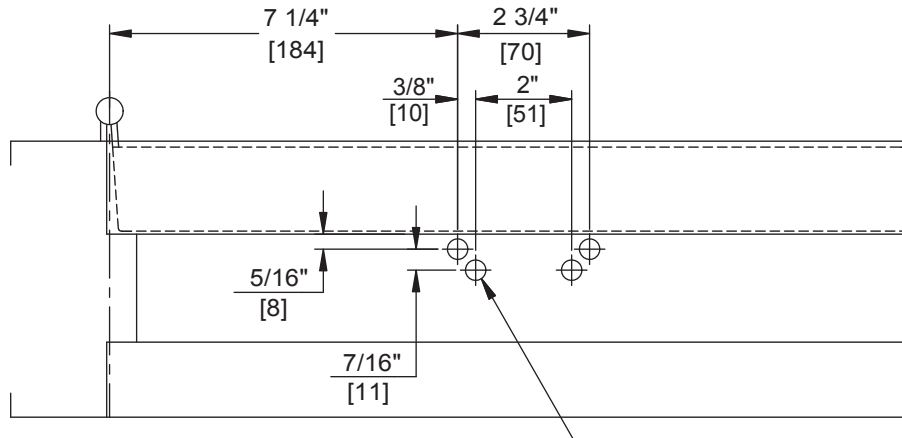

FOR 1/4-20 MACHINE SCREWS USE 7/32" DRILL
FOR No.14 WOOD SCREWS USE 5/32" DRILL
DPK FASTENERS DRILL 1/8" PILOT HOLE
FOUR (4) HOLES IN FRAME FOR PA BRACKET

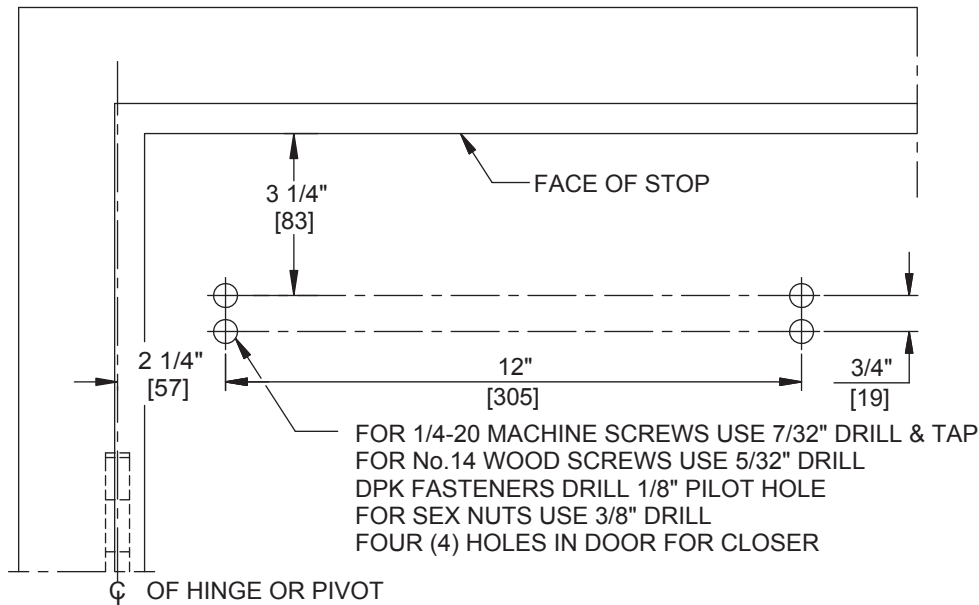

FOR 1/4-20 MACHINE SCREWS USE 7/32" DRILL & TAP
FOR No.14 WOOD SCREWS USE 5/32" DRILL
DPK FASTENERS DRILL 1/8" PILOT HOLE
FOR SEX NUTS USE 3/8" DRILL
FOUR (4) HOLES IN DOOR FOR CLOSER

NOTES:

1. DO NOT SCALE DRAWING.
2. DIMENSIONS ARE IN INCHES/(MM).
3. LEFT HAND DOOR SHOWN.
4. CAUTION: SEX NUTS ARE REQUIRED FOR ATTACHMENT OF COMPONENTS TO UNREINFORCED DOORS AND TO WOOD OR PLASTIC FACED COMPOSITE TYPE FIRE DOORS, UNLESS AN ALTERNATIVE METHOD IS IDENTIFIED IN THE INDIVIDUAL DOOR MANUFACTURER'S LISTINGS.
5. MAX. OPENING IS 180°.
6. HOLD OPEN RANGE 30° - 100°.
7. DPK FASTENERS FOR STEEL DOOR & FRAME ONLY.

